

# ezPAC™

## SA300 Series SUBSTATION AUTOMATION UNIT SA310/SA320/SA330

### Installation Manual

---



BG0325 Rev. D

## LIMITED WARRANTY

The manufacturer offers the customer an 24-month functional warranty on the instrument for faulty workmanship or parts from date of dispatch from the distributor. In all cases, this warranty is valid for 36 months from the date of production. This warranty is on a return to factory basis.

The manufacturer does not accept liability for any damage caused by instrument malfunction. The manufacturer accepts no responsibility for the suitability of the instrument to the application for which it was purchased.

Failure to install, set up or operate the instrument according to the instructions herein will void the warranty.

Your instrument may be opened only by a duly authorized representative of the manufacturer. The unit should only be opened in a fully anti-static environment. Failure to do so may damage the electronic components and will void the warranty.

### NOTE


The greatest care has been taken to manufacture and calibrate your instrument. However, these instructions do not cover all possible contingencies that may arise during installation, operation or maintenance, and all details and variations of this equipment are not covered by these instructions.

For additional information regarding installation, operation or maintenance of this instrument, contact the manufacturer or your local representative or distributor.

### IMPORTANT

**Please read the instructions in this manual before performing installation, and take note of the following precautions:**

1. **Ensure that all incoming AC power and other power sources are turned OFF** before performing any work on the instrument. Failure to do so may result in serious or even fatal injury and/or equipment damage.
2. **Before connecting the instrument to the power source, check** the labels on the side of the instrument to ensure that your instrument is equipped with the appropriate power supply voltage, input voltages, currents, analog output and communication protocol for your application.
3. **Do not** connect the instrument to a power source if it is damaged.
4. **Do not** expose the instrument to rain or moisture.
5. **The secondary of an external current transformer must never be** allowed to be open circuit when the primary is energized. An open circuit can cause high voltages, possibly resulting in equipment damage, fire and even serious or fatal injury. Ensure that the current transformer wiring is made through shorting switches and is secured using an external strain relief to reduce mechanical strain on the screw terminals, if necessary.
6. **Setup procedures must be performed only by qualified** personnel familiar with the instrument and its associated electrical equipment.
7. **DO NOT insert or remove I/O modules if the instrument is ON.**
8. **DO NOT open the instrument under any circumstances.**

 **Read this manual thoroughly before connecting the meter to the current carrying circuits. During operation of the meter, hazardous voltages are present on input terminals. Failure to observe precautions can result in serious or even fatal injury or damage to equipment.**

# Table of Contents

<b>Chapter 1 Introduction .....</b>	<b>1</b>
1.1 About This Manual .....	1
1.2 About The SA300.....	1
<b>Chapter 2 Installation .....</b>	<b>4</b>
2.1 Mechanical Installation .....	4
2.2 Electrical Installation.....	8
2.3 Location of Modules.....	25
<b>Chapter 3 Communications .....</b>	<b>26</b>
<b>Chapter 4 Changing the Battery .....</b>	<b>32</b>
<b>Appendix: Technical Specifications .....</b>	<b>33</b>

# Chapter 1 Introduction

## 1.1 About This Manual

This manual is intended to assist the user in the installation of the *SA300 Series (ezPAC™) Substation Automation Unit*. The term 'SA300' is used herein to refer to all models in the series.

This chapter gives an overview of this manual and an introduction to the SA300.

Chapter 2, *Installation*, provides instructions for mechanical and electrical installation.

Chapter 3, *Communications*, provides drawings for communications connections and instructions for printing electrical parameter readings.

Technical Specifications for the SA300 are found in the *Appendix*.

## 1.2 About The SA300

The SA300 series is a group of advanced multi-microprocessor-based digital instruments that incorporate the capabilities of a power quality analyzer, energy meter, fault and data recorder and programmable controller, oriented for substation automation. These instruments provide three-phase measurements of electrical quantities in power distribution systems, monitoring external events, operating external equipment via relay contacts, fast and long-term on-board recording of measured quantities, faults with currents up to 150A and events, harmonic network analysis and disturbance recording.

The unit is available in three models:

- SA310 - Basic Fault model - offers all the basic metering, control, and fault and event recording capabilities
- SA320 - Power Quality model - adds an IEEE 1159 power quality recorder and reports
- SA330 - Premium model - adds four 10A/20A current inputs for precise energy metering and management, keeping the standard 150A current inputs for fault recording

### Features

The SA300 combines in a single enclosure:

- Digital Fault Recorder (onboard fault detector - programmable fault thresholds and hysteresis, up to 150 Amps fault currents, zero-sequence currents and volts, current and volt unbalance; up to 48 external digital triggers from tripping protection relays; ready-for-use fault reports - fault currents magnitude and duration, coincident volts magnitude, fault waveforms and RMS trace)
- Precise Sequence-of-Events Recorder (up to 96 digital inputs at 1-ms resolution, fault events and relay operations)
- EN50160 Power Quality recorder (EN50160 compliance statistics, EN50160 harmonics survey statistics, onboard power quality analyzer; programmable thresholds and hysteresis; ready-for use reports)
- GOST13109-97 (Russian Power Quality standard) onboard power quality analyzer; programmable thresholds and hysteresis; ready-for use reports)
- Power Quality Recorder (IEEE 1159, onboard PQ analyzer; programmable thresholds and hysteresis; ready-for-use reports; transients, impulses, sags/swells, interruptions, harmonics, inter-harmonics, frequency variations, volts unbalance)
- Event Recorder for logging internal diagnostics events, control events and I/O operations
- Eight fast Waveform Recorders (simultaneous 8-channel AC, VDC and 16-channel digital inputs recording in a single plot; selectable AC sampling rate of 32, 64 or 128 samples per cycle; 20 pre-fault cycles, 1-ms resolution for digital inputs; up to 3 min of continuous recording with a **4-Mbyte onboard memory** at a rate of 32 samples per cycle)
- Sixteen fast Data Recorders (from 1/2 cycle RMS to 2-hour RMS envelopes; up to 20 pre-fault cycles; programmable data logs on a periodic basis and on any internal and external trigger)

- Programmable Controller (32 control setpoints, OR/AND logic, extensive triggers, programmable thresholds and delays, relay control, event-driven data recording). Ability to block relay outputs with a special control algorithm.
- High-Class 3-phase Power meter (true RMS, volts, amps, powers, power factors, unbalance, neutral current)
- Demand Meter (amps, volts, harmonic demands)
- Precise Energy and Power Demand Meter (TOU, 16 Summary energy and demand registers for substation energy management, accumulation of energy pulses from external watt-meters, block and sliding demands, up to 64 energy sources)
- Harmonic Analyzer (to 63rd harmonic volts and amps, directional power harmonics and power factor, phasors, symmetrical components)
- 32 digital counters for counting pulses from external sources and numerous internal events
- 16 programmable timers from 1/2 cycle to 24 hours for periodic recording and triggering operations on a time basis
- 1-ms satellite-synchronized clock (IRIG-B time-code input)
- SNTP Time Synchronization thru Ethernet port.
- Second backup power supply unit.

Additionally, the SA300 can be equipped with a 64/128-Mbyte Expansion Memory plug-in module for long-term waveform recording.

### **AC/DC Inputs**

The SA300 is provided with a set of fully isolated AC/DC inputs for a connection to the AC feeders and station battery:

- Four isolated AC voltage inputs (up to 690VAC direct line-to-line input voltage)
- Four standard isolated AC current inputs with an extended input range up to  $\times 3000\%$  overload (10A/IEC or 20A/ANSI input currents, to 150 Amps fault currents)
- Optional second set of four isolated current inputs (10A/IEC or 20A/ANSI input currents) for precise energy metering
- DC voltage input (up to 300VDC) for monitoring the station battery

### **Digital and Analog I/O Options**

The SA300 has five I/O expansion slots for removable plug-in I/O modules:

- DI - Digital inputs (16 or 32 optically isolated inputs per module, up to 3 modules per device; options for dry contacts, and wet inputs; programmable de-bounce time from 1 ms to 1 sec; free linkage to Sequence-of-Events Recorder, Fault Recorder, control setpoints, pulse counters and Energy/TOU subsystem)
- RO - Relay outputs (8 or 16 relays per module, up to 4 modules per device; unlatched, latched and pulse operations, failsafe operation for alarm notifications; programmable pulse width; direct remote relay control through communications)
- AI/AO - Mixed analog input/output modules (four optically isolated AI and four AO with internal power supplies per module, up to 4 modules per device; options for 0-1mA,  $\pm 1$ mA, 0-20mA and 4-20mA inputs and outputs;  $\times 200\%$  overload current for 0-1mA and  $\pm 1$ mA AI/AO)

### **Communications Options**

The SA300 has extensive communications capabilities:

- Three independent universal serial communications ports (RS-232, RS-422/RS-485, up to 115,200 bps, Modbus RTU/ASCII and DNP3.0 protocols)
- Infrared port (Modbus RTU/ASCII and DNP3.0 protocols)
- Embedded 56K modem for communications through public telephone lines (Modbus RTU/ASCII and DNP3.0 protocols)
- Ethernet 10Base-T port (Modbus/TCP or DNP3.0/TCP protocols, up to five non-intrusive simultaneous connections, Telnet service port)
- USB 1.1 port (Modbus RTU protocol, 12 Mbps) for fast local communications and data retrieving

### ***Remote Displays***

The SA300 can be ordered with an optional LED Remote Display Module (RDM) or LCD Remote Graphical Module (RGM). Both have a fast RS-485 port and communicate with the SA300 through the Modbus RTU protocol. Remote displays can be located at distances of up to 0.5 km from the device. The RGM can also be ordered with an Ethernet 10Base-T port and can communicate with the SA300 through a local network.

The RDM has three six-digit windows with bright red LEDs well suited for dark areas. It allows the user to view real-time RMS and harmonics measurements, status indication parameters, and perform basic setup operations when installing and servicing the device.

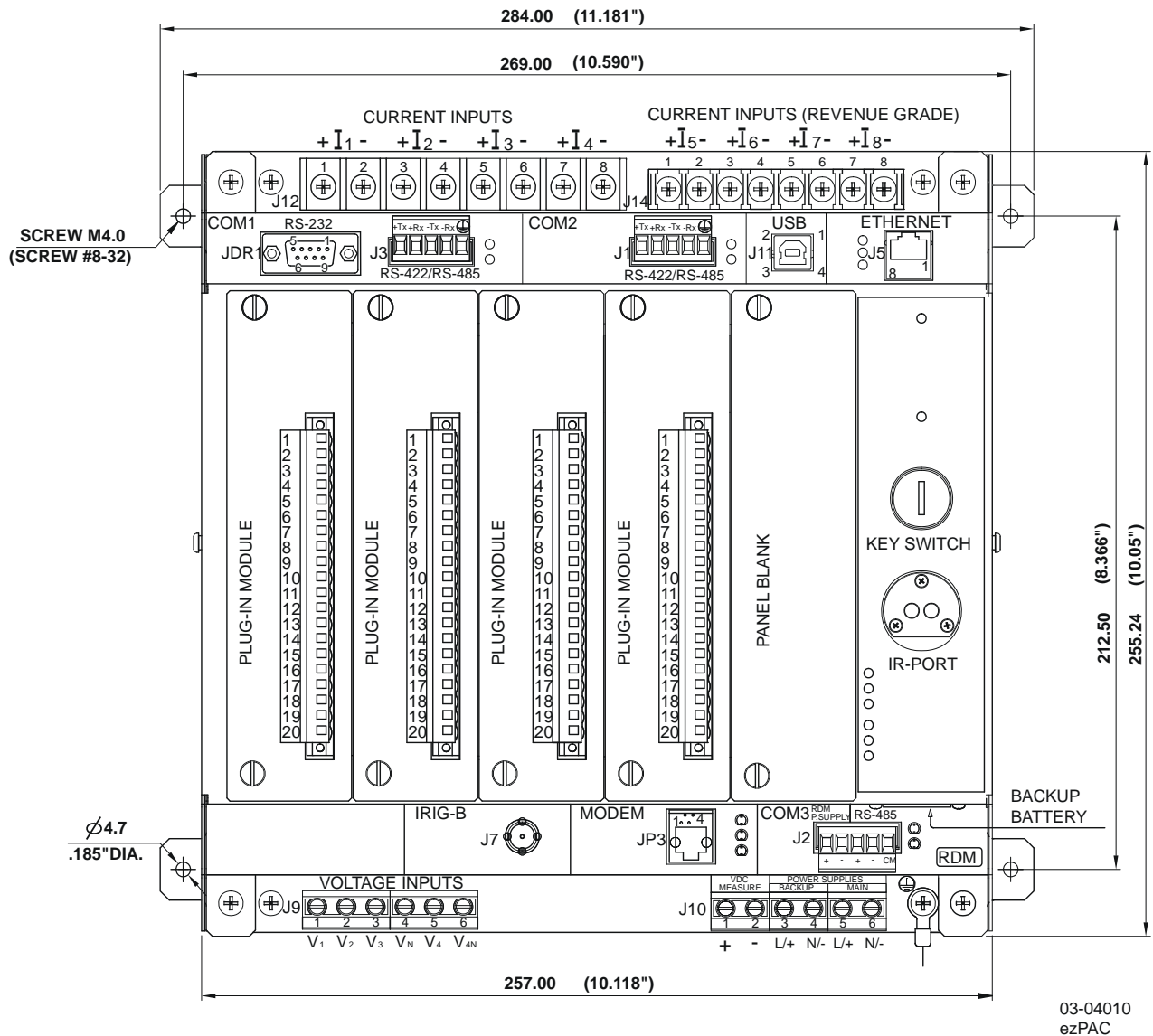
The RGM is equipped with a color graphics LCD display and has extensive dialog capabilities, allowing the user to view different fault and power quality information in a graphical form, such as waveforms, harmonic spectrum, phasor and data trends, review latest fault and power quality reports for fast fault analysis, and much more.

### ***Upgradeable Firmware***

The SA300 uses flash memory for storing device firmware that allows future upgrading of the device without replacing any hardware component. The new features can be easily added to your device by simply replacing the firmware through a local RS-232 port or Ethernet port.

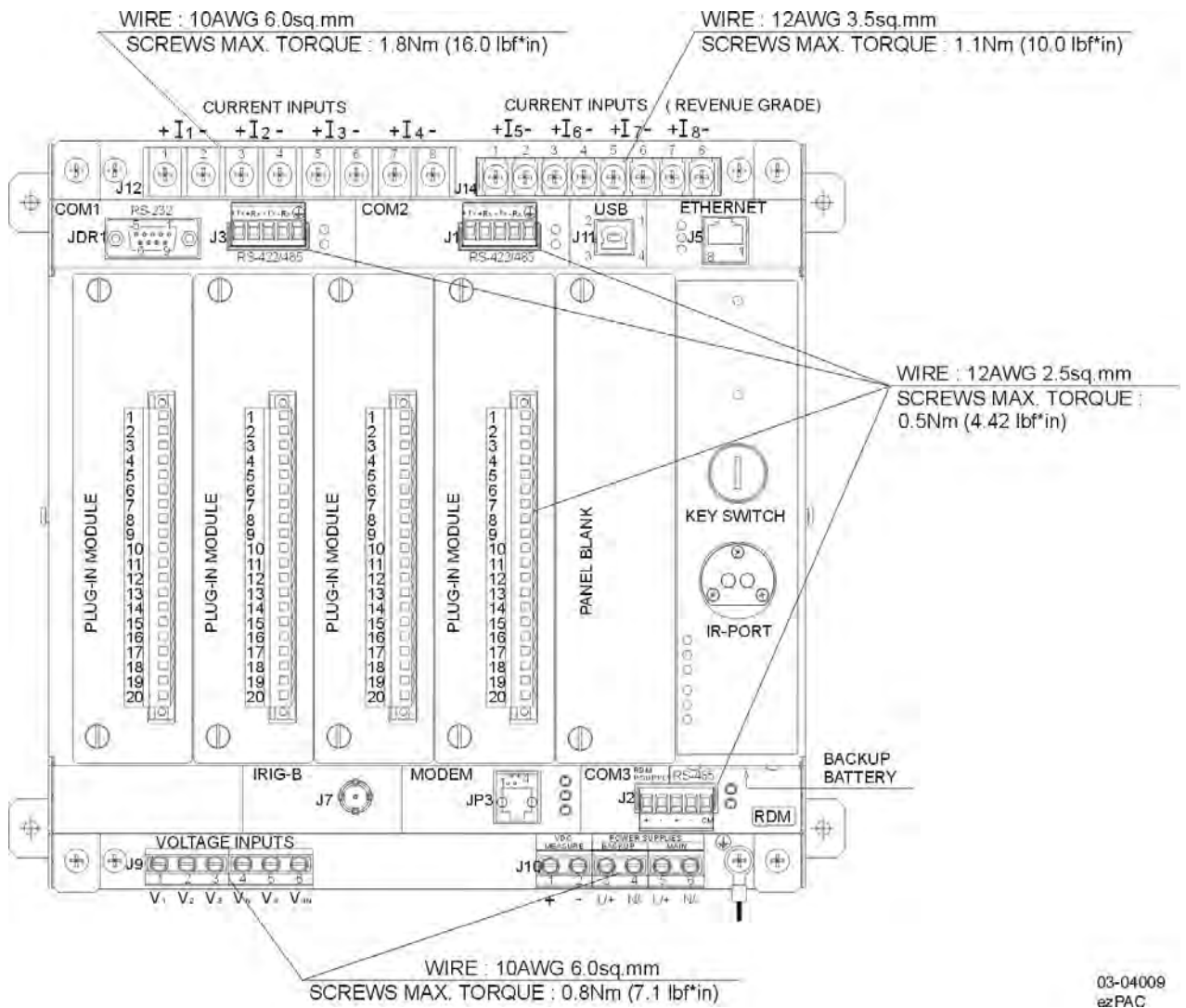
# Chapter 2 Installation

## 2.1 Mechanical Installation



03-04010  
ezPAC

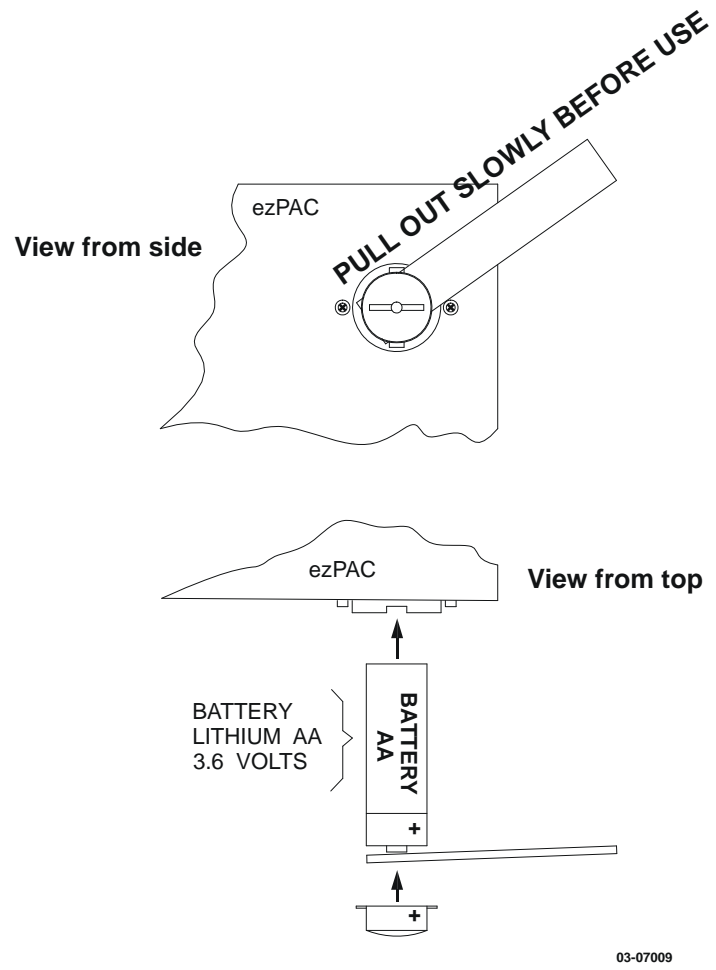
Figure 2-1a Dimensions



03-04009  
ezPAC

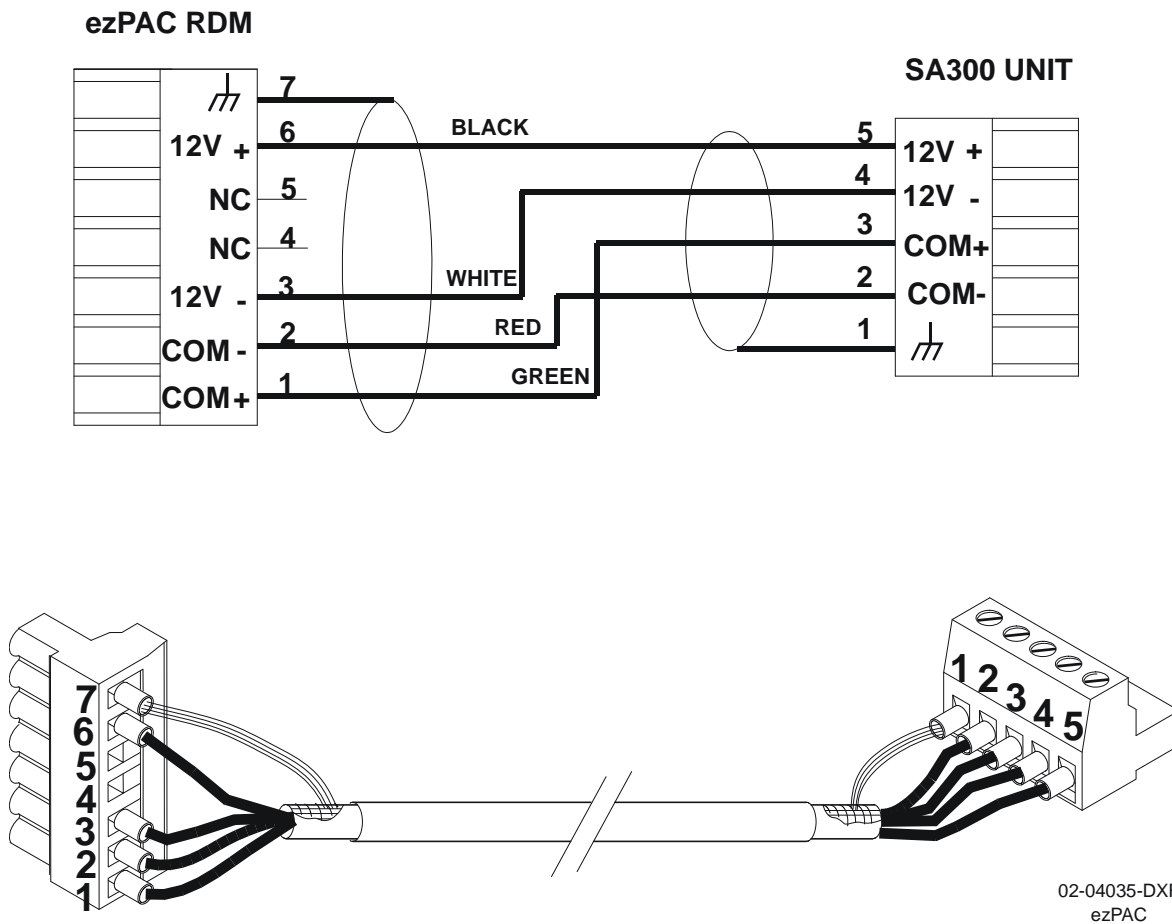
**Figure 2-1b** Mounting





**Figure 2-1c** Activating the Battery

The ezPac display module is connected to the communication connector of the SA300 unit as shown in *Figure 2-2*.



**Figure 2-2** ezPac RDM Connection

## 2.2 Electrical Installation

### 2.2.1 Power Source Connection

The SA300 unit has two independent power supplies: main and backup. The standard power supplies may be connected to an 85-265V AC or 88-290V DC power source. Lower voltage DC power supply options are also available (see *Appendix: Technical Specifications*).

The main power supply connections are:

- AC power: line to terminal J10 5; neutral to terminal J10 6.
- DC power: positive to terminal J10 5; negative to terminal J10 6.

The backup power supply connections:

- AC power: line to terminal J10 3; neutral to terminal J10 4.
- DC power: positive to terminal J10 3; negative to terminal J10 4.

Copper wiring 1.5-2.5 mm<sup>2</sup> (15 -13 AWG) should be used.

### 2.2.2 Current Inputs

SA310 and SA320 models have 4 current inputs up to 150A, connected to Relay Protection CT's via J12 connector. Copper wiring 2.5 – 6 mm<sup>2</sup> (10 AWG) should be used.

SA330 model has 4 additional current inputs up to 20A (ANSI) or 10A (IEC), connected to metering CTs via J14 connector. Copper wiring 1.5 – 3.5 mm<sup>2</sup> (12 AWG) should be used.

### 2.2.3 Ground

Connect the chassis ground of the SA300 to the switchgear earth ground using dedicated wire greater than 2 mm<sup>2</sup>/14 AWG.

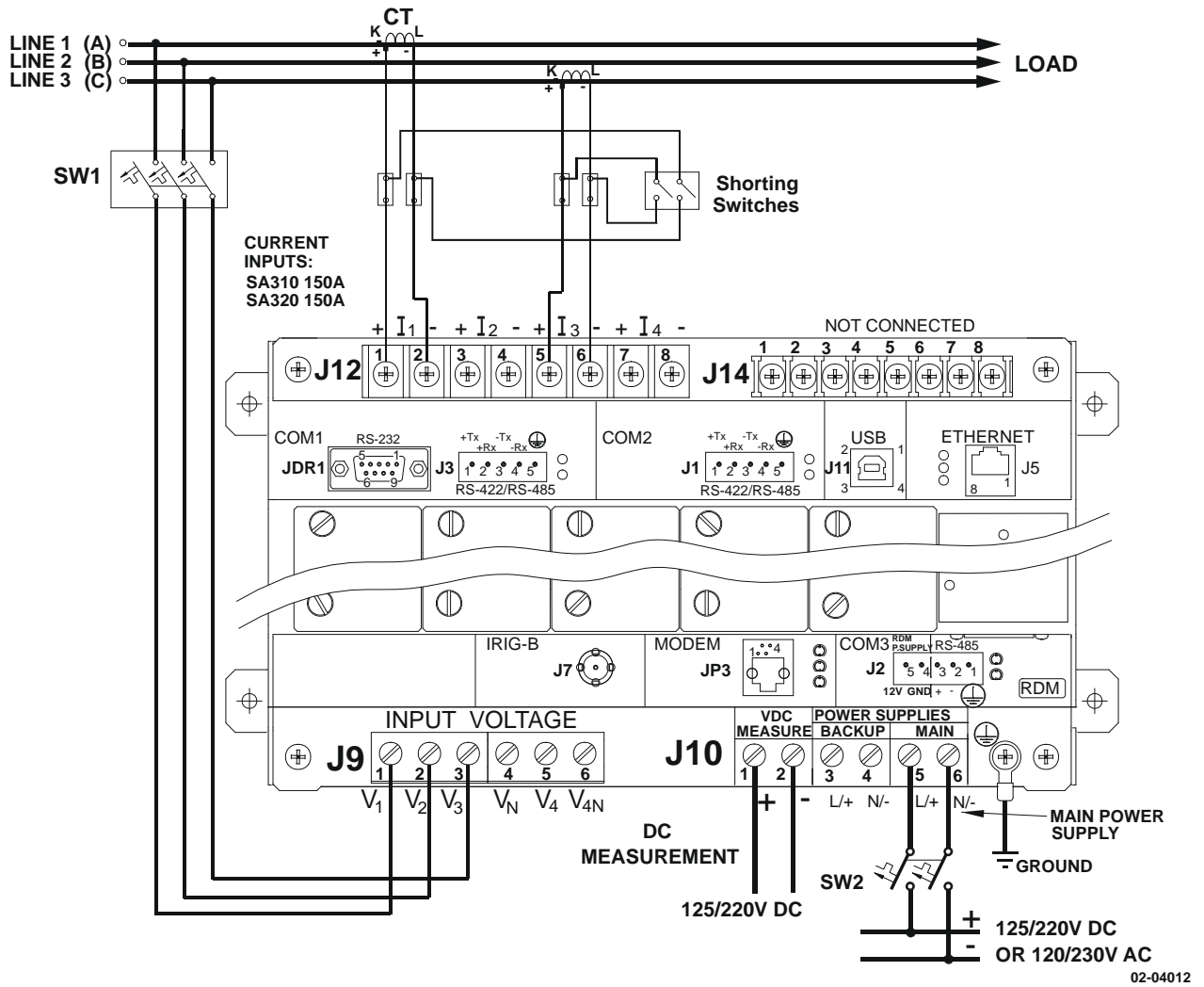
### 2.2.4 Voltage Inputs

SA300 models have 3 AC Y-connected voltage inputs of 690V (phase-to-phase) and neutral, and one separate isolated AC voltage input of 400V.

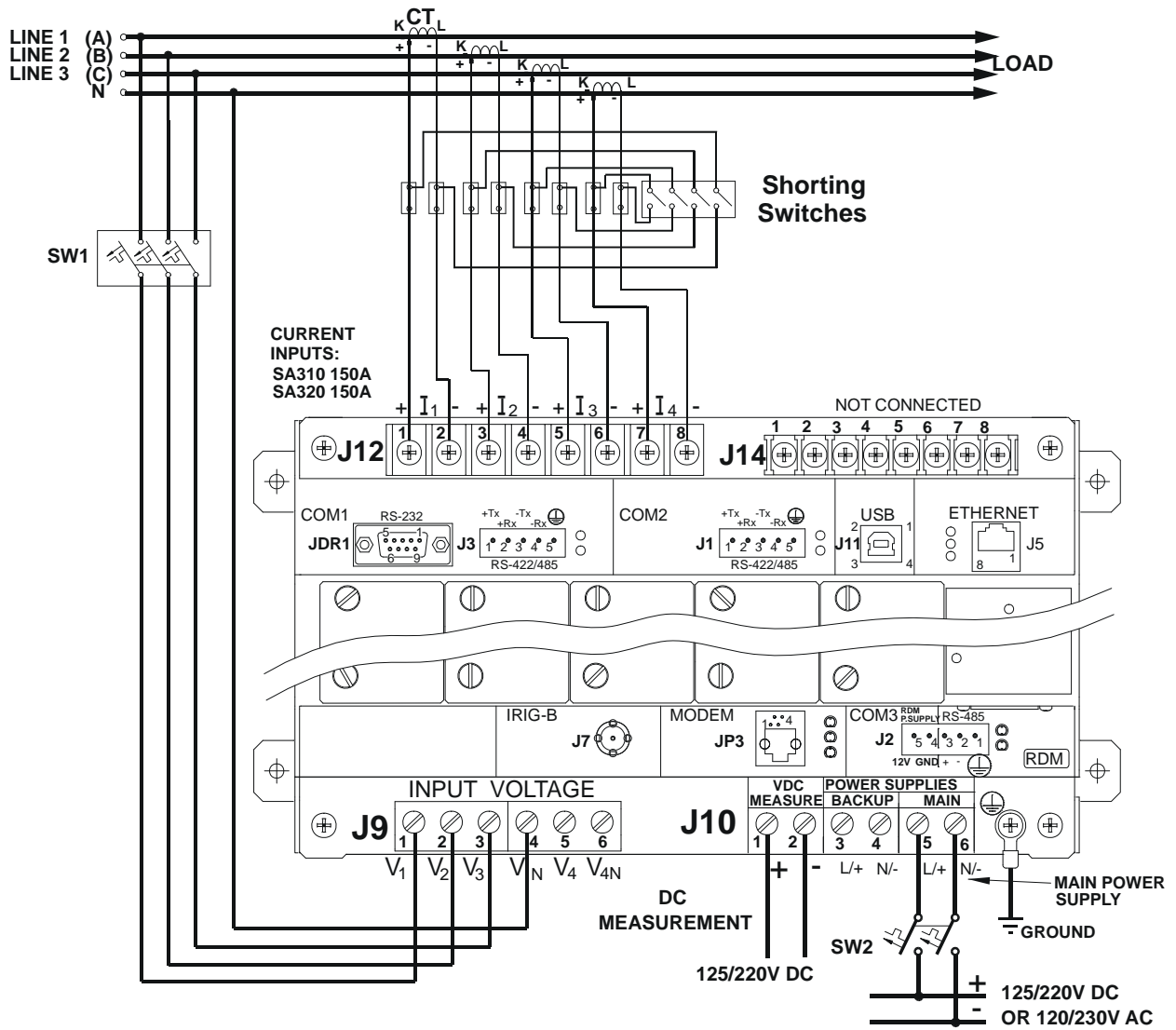
### 2.2.5 Wiring Configurations

For models SA310, SA320, use any of the seven wiring configurations shown in Figures 2-3, 2-4, 2-5, 2-6, 2-7, 2-8 or 2-9; for model SA330, use any of the four wiring configurations shown in Figures 2-5a, 2-6a, 2-7a or 2-8a.

Wiring Configuration (See parameter setup instructions in Section 4.1)	Wiring		
	Model	Code for Setup	See Figure:
3-wire direct connection using 2 CTs (2-element)	SA310, SA320	3dir2	2-3
4-wire WYE direct connection using 4 CTs (3-element)	SA310, SA320	4Ln4 or 4LL4	2-4
4-wire WYE connection using 3 PTs, 3 CTs (3-element)	SA310, SA320	4Ln3 or 4LL3	2-5
4-wire WYE connection using 3 PTs, 3 CTs (3-element)	SA330	4Ln3 or 4LL3	2-5a
3-wire open delta connection using 2 PTs, 2 CTs (2-element)	SA310, SA320	3OP2	2-6
3-wire open delta connection using 2 PTs, 2 CTs (2-element)	SA330	3OP2	2-6a
4-wire WYE connection using 2 PTs, 3 CTs (2½-element)	SA310, SA320	3Ln3 or 3LL3	2-7
4-wire WYE connection using 2 PTs, 3 CTs (2½-element)	SA330	3Ln3 or 3LL3	2-7a
3-wire open delta connection using 2 PTs, 3 CTs (2½-element)	SA310, SA320	3OP3	2-8
3-wire open delta connection using 2 PTs, 3 CTs (2½-element)	SA330	3OP3	2-8a
4-wire delta direct connection using 3 CTs (3-element)	SA310, SA320	4Ln3 or 4LL3	2-9

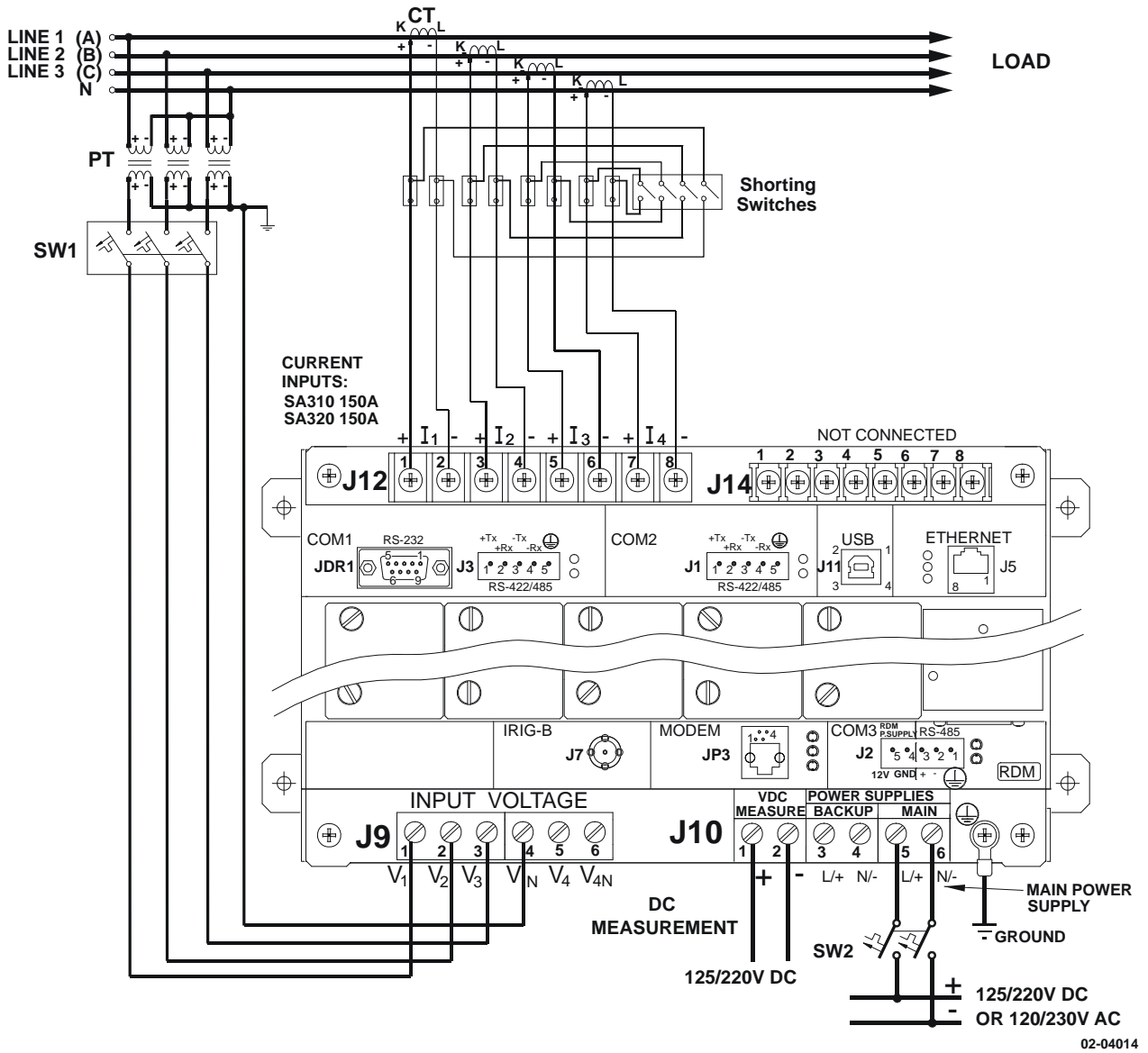


**Figure 2-3**  
**SA310, SA320:** Three Wire Direct Connection Using 2 CTs (2-element)  
 Wiring Mode = **3dir2**



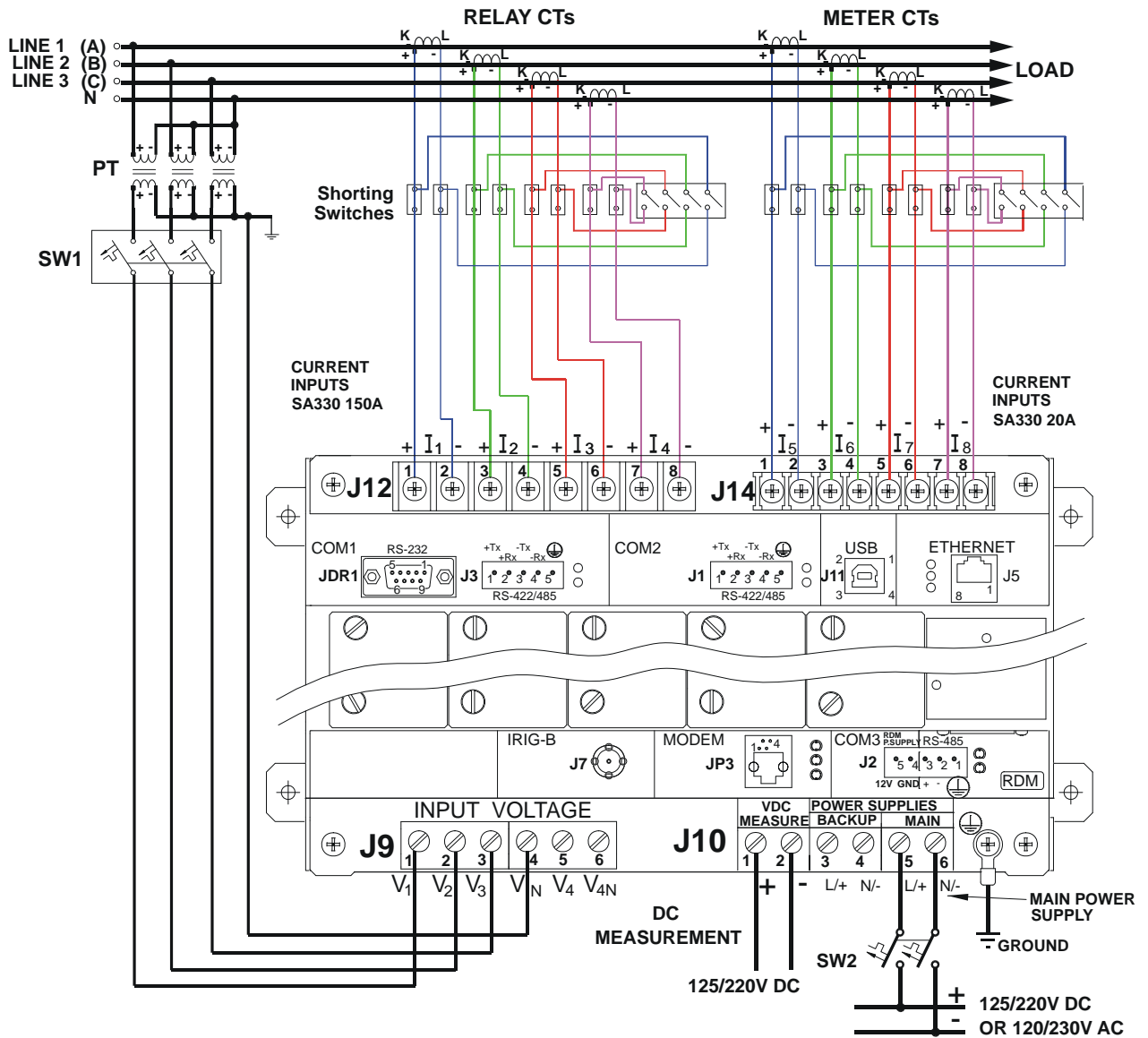
02-04013

**Figure 2-4**  
**SA310, SA320:** Four Wire WYE Direct Connection Using 4 CTs (3-element)  
 Wiring Mode = 4LL4 or 4Ln4



**Figure 2-5**  
**SA310, SA320:** Four Wire WYE Connection Using 3 PTs, 4 CTs  
 (3-element)

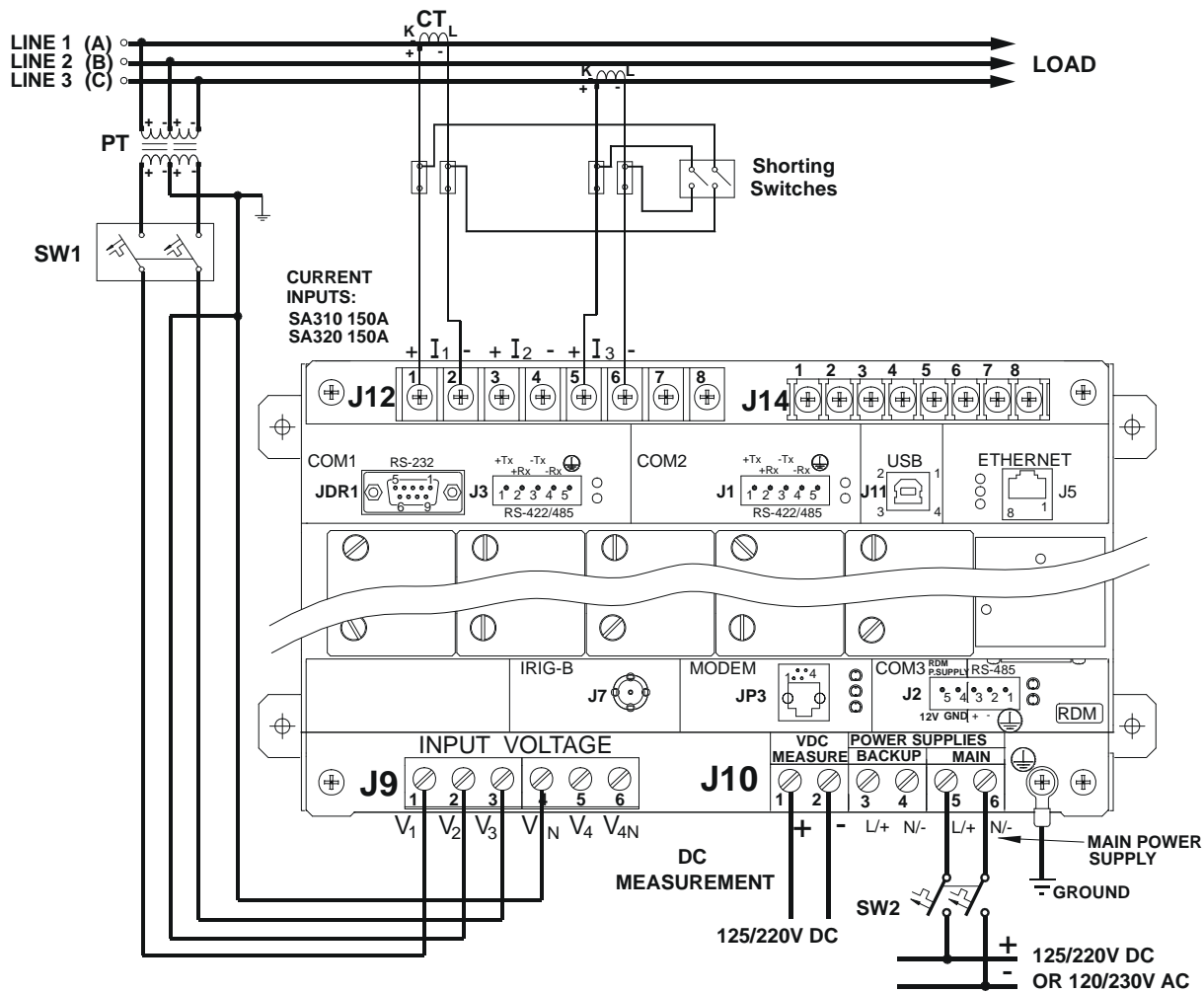
Wiring Mode = 4LL4 or 4Ln4



**Figure 2-5a**  
**SA330:** Four Wire WYE Connection Using 3 PTs, 4 CTs  
 (3-element)

Wiring Mode = 4LL4 or 4Ln4

03-05003

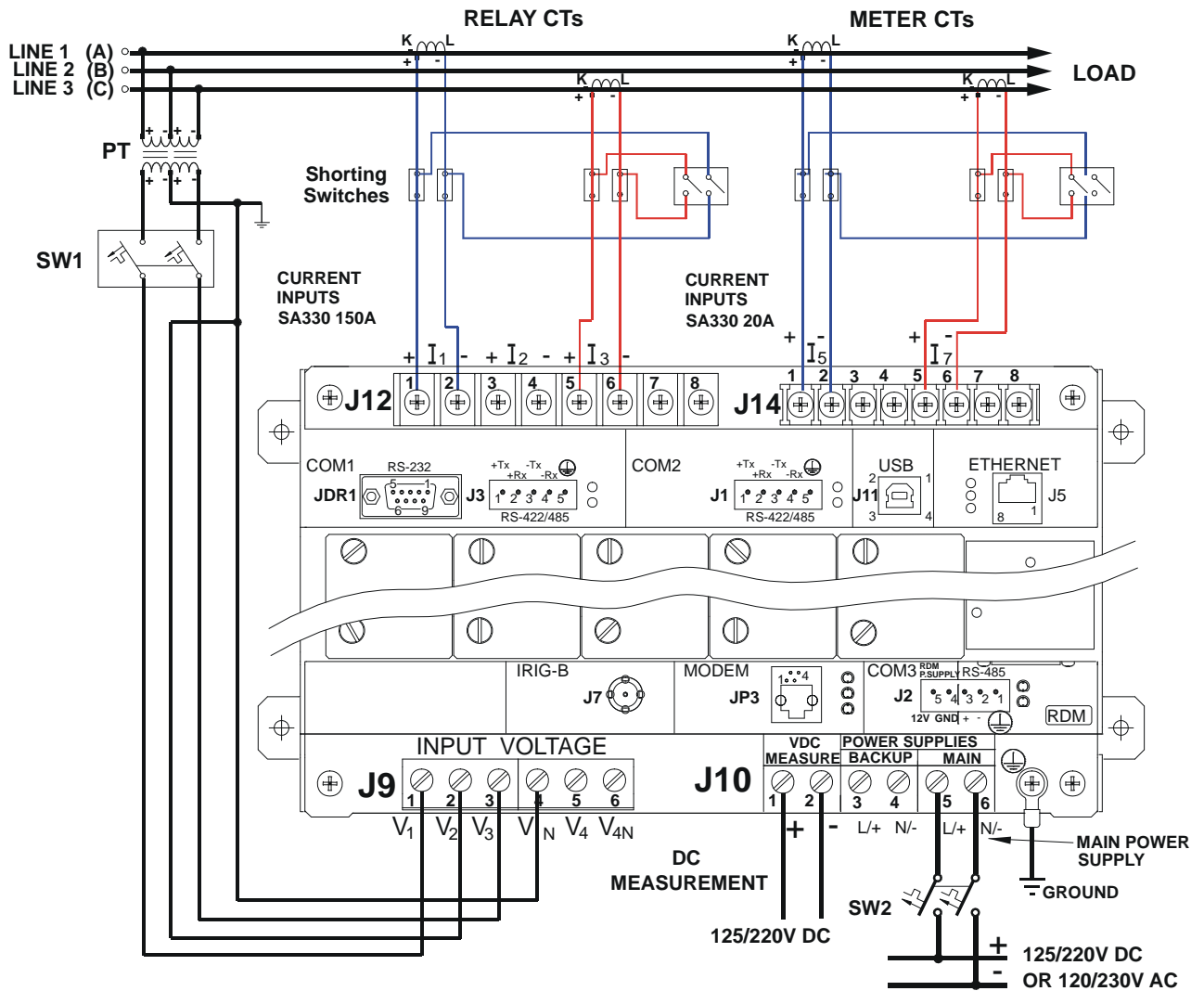


02-04015

**Figure 2-6**  
**SA310, SA320:** Three Wire Open Delta Connection Using 2 PTs, 2 CTs (2-element)

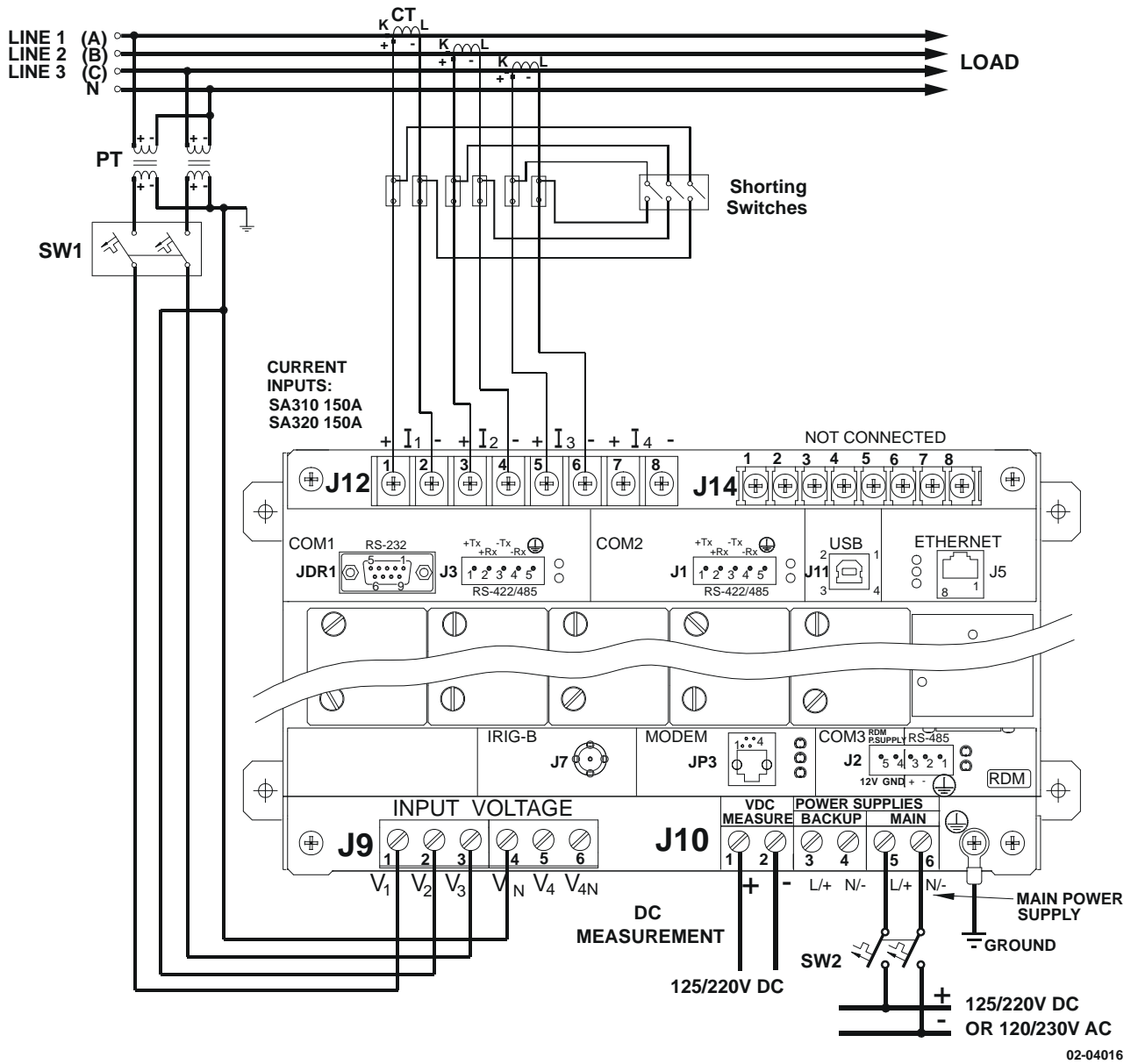
Wiring Mode = 30P2



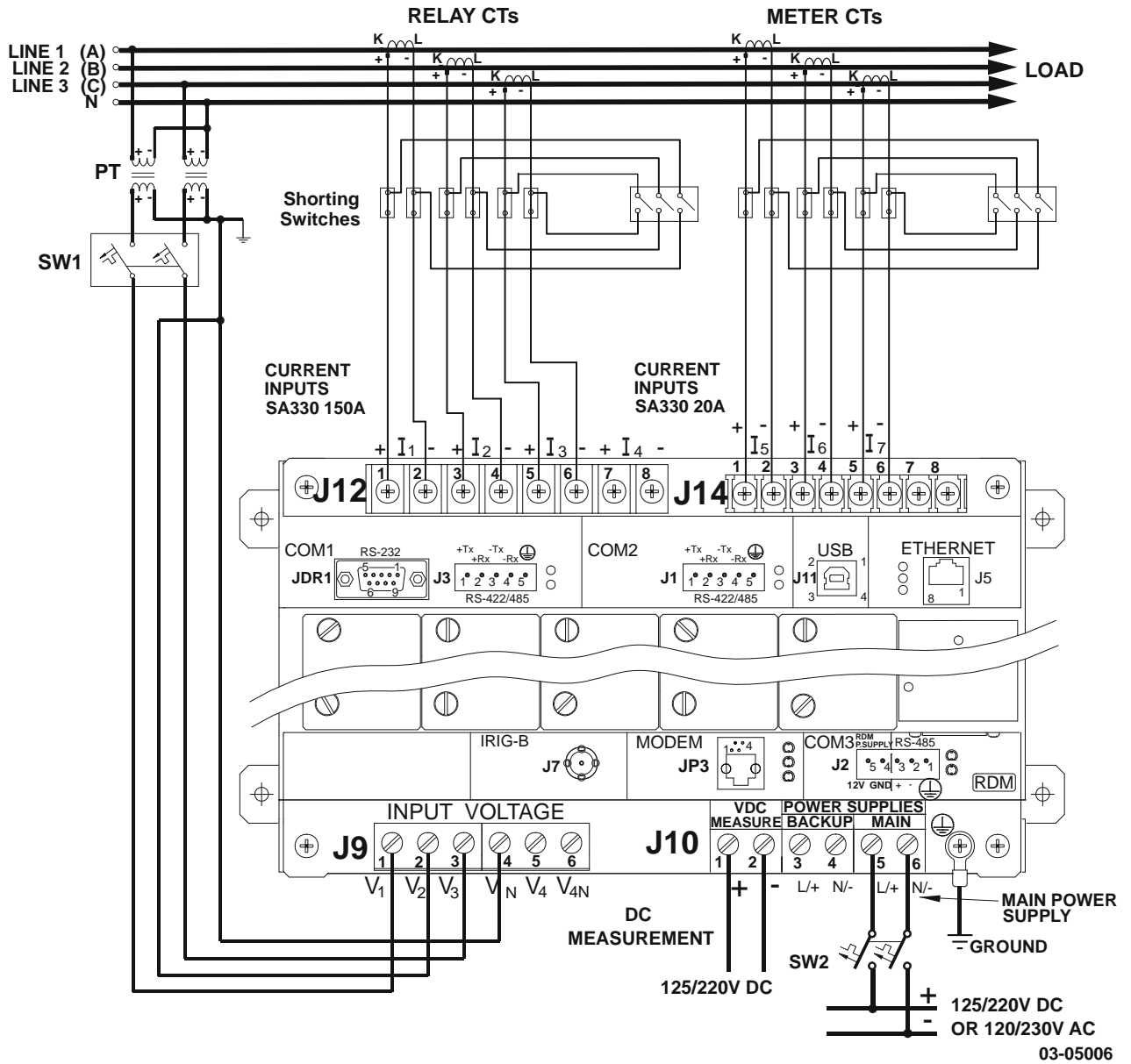


**Figure 2-6a**  
**SA330:** Three Wire Open Delta Connection Using 2 PTs, 2 CTs (2-element)  
 Wiring Mode = **3OP2**

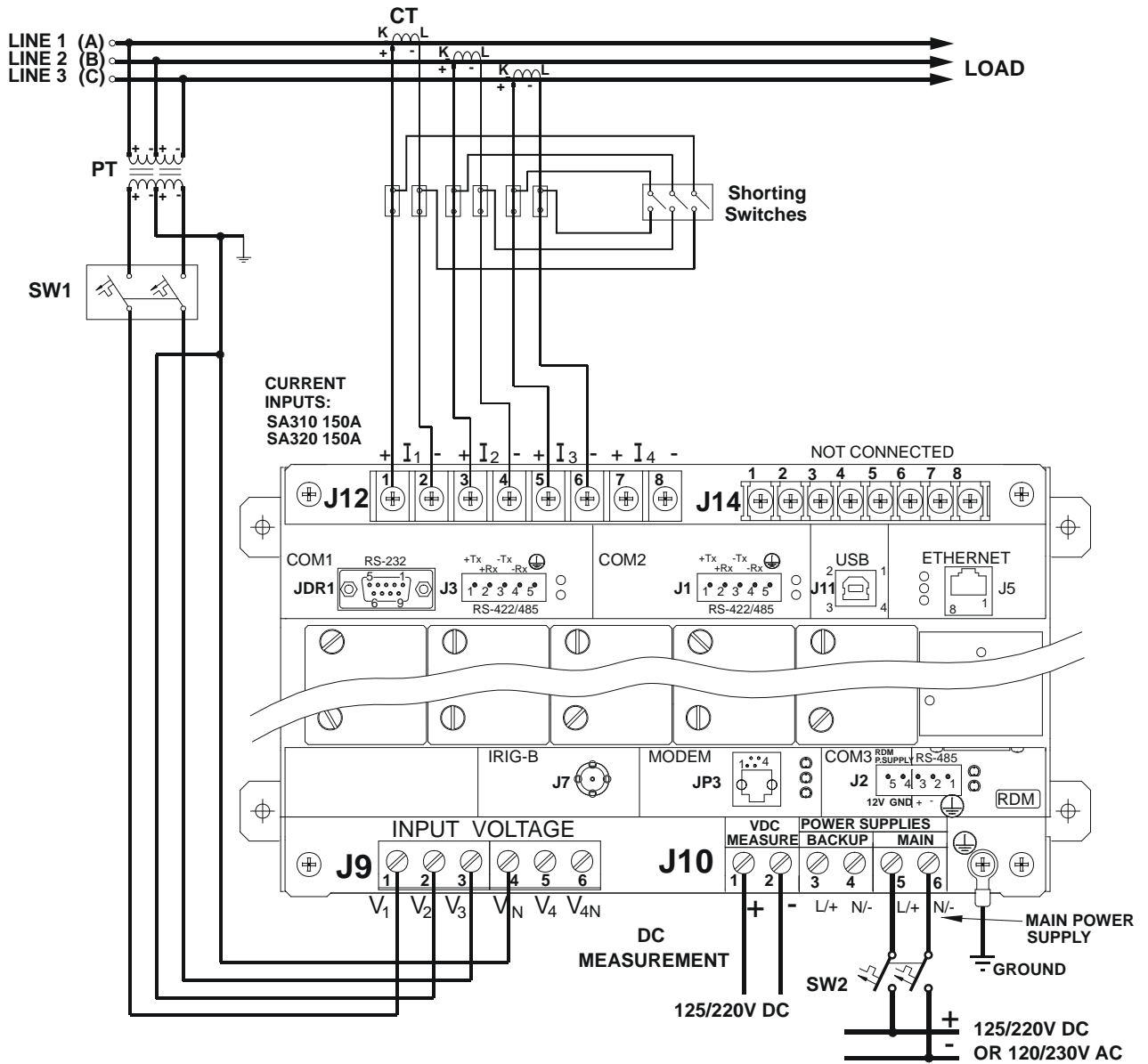
03-05005



**Figure 2-7**  
**SA310, SA320:** Four Wire Wye Connection Using 2 PTs, 3 CTs (2½-element)  
 Wiring Mode = 3LL3 or 3Ln3

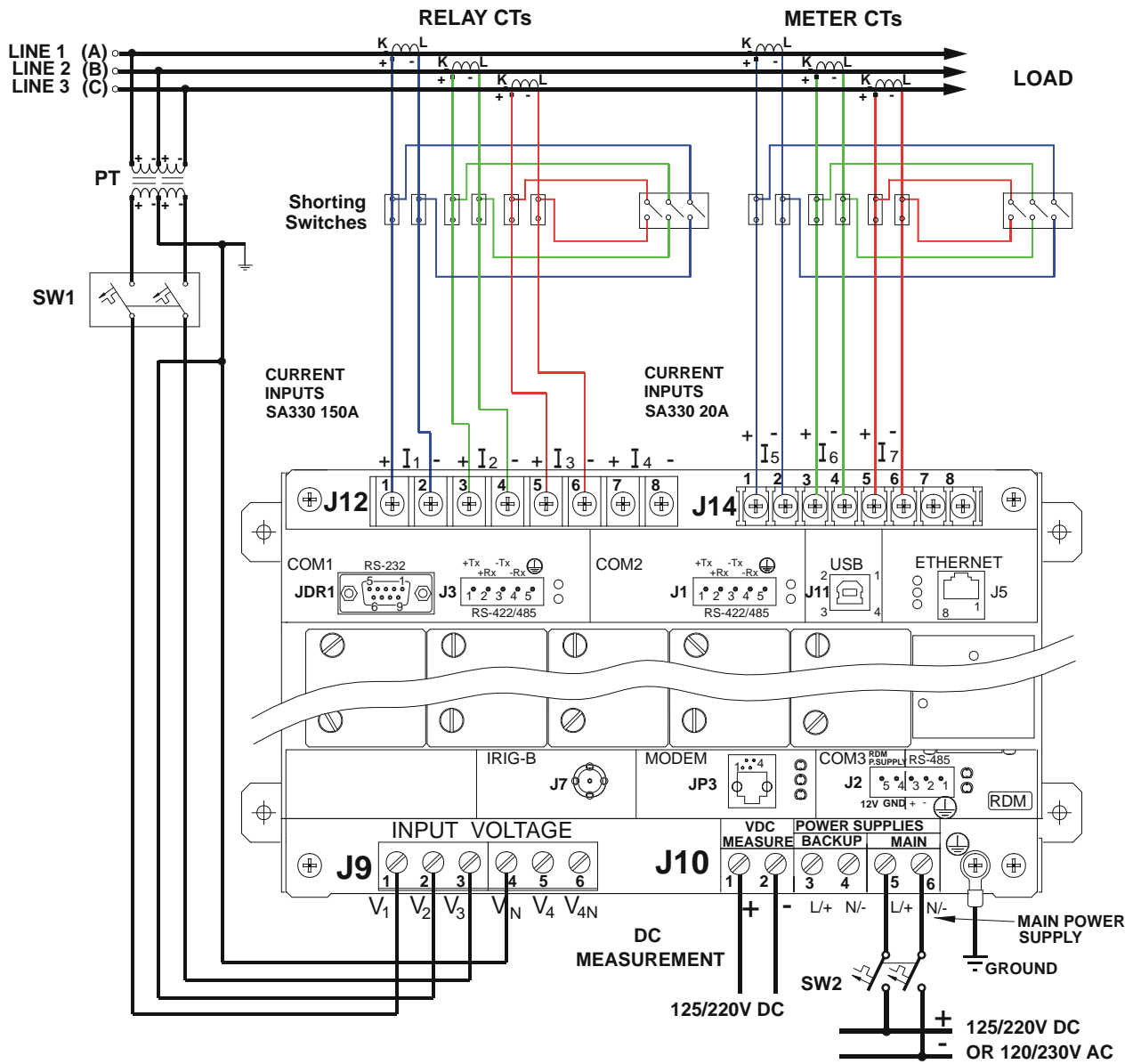


**Figure 2-7a**  
**SA330: Four Wire Wye Connection Using 2 PTs, 3 CTs** (2½-element)  
 Wiring Mode = **3LL3** or **3Ln3**



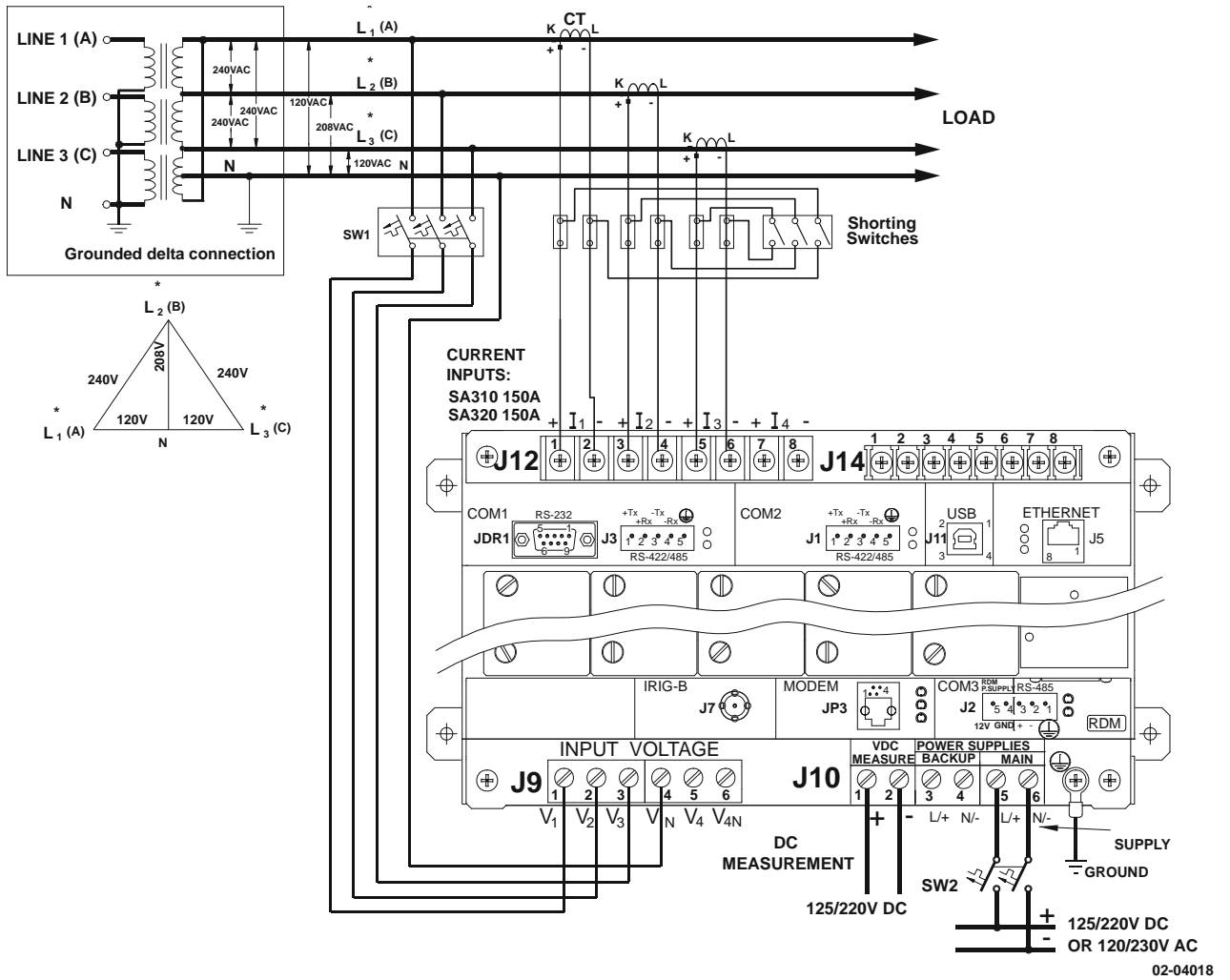
02-04017

**Figure 2-8**  
**SA310, SA320: Three Wire Open Delta Connection Using 2 PTs, 3 CTs (2½-element)**  
Wiring Mode = 3OP3



**Figure 2-8a**  
**SA330:** Three Wire Open Delta Connection Using 2 PTs, 3 CTs (2½-element)  
 Wiring Mode = **3OP3**

03-05004



**Figure 2-9**  
**SA310, SA320: Four Wire Delta Direct Connection Using 3 CTs** (3 element)  
 Wiring Mode = 4LL3 or 4Ln3

## 2.2.6 Digital Inputs

There are two possible module types:

- a) 16 Digital Inputs,
- b) 16x2 (32) Digital Inputs.

Optically isolated digital inputs in one digital input module are provided for status monitoring and external synchronization of power demand period and time. Dry or wet contacts may be connected to these inputs, as shown in *Figures 2-10, 11, 12, and 13*.

In 16-DI Variant the common terminals are internally connected together, in 32-DI variant the module has 8 independent isolated circuits, containing 4 inputs with one common terminal.

### Dry Contacts

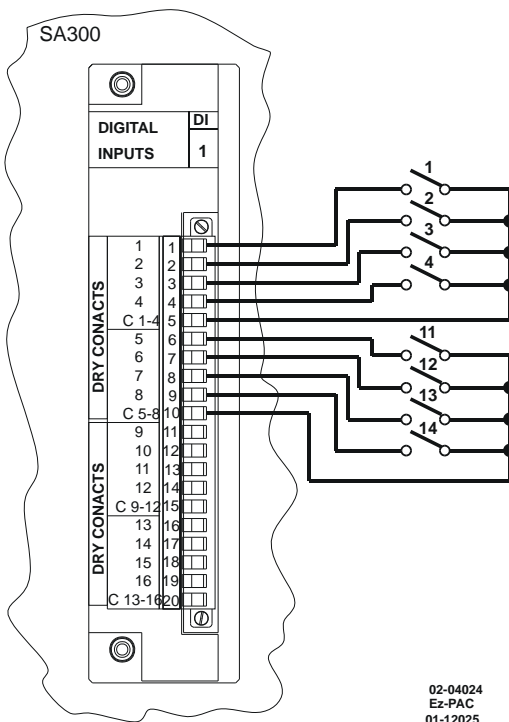


Figure 2-10 16-DI Connection for Dry Contacts

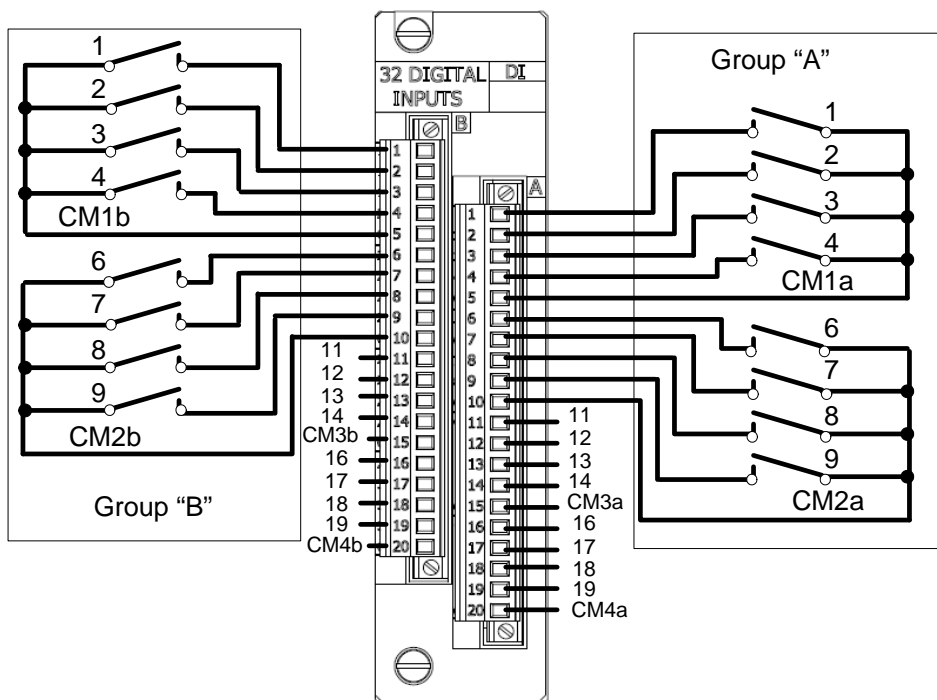
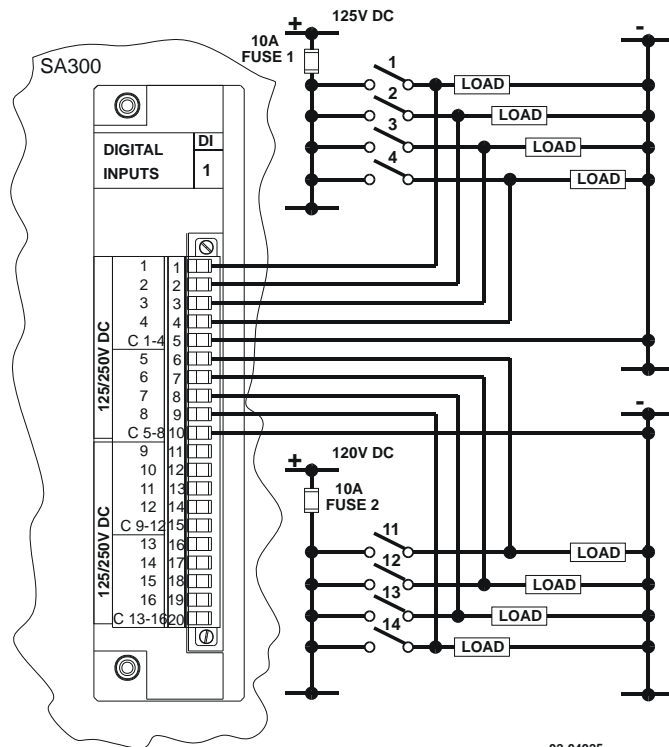


Figure 2-11 32-DI Connection for Dry Contacts

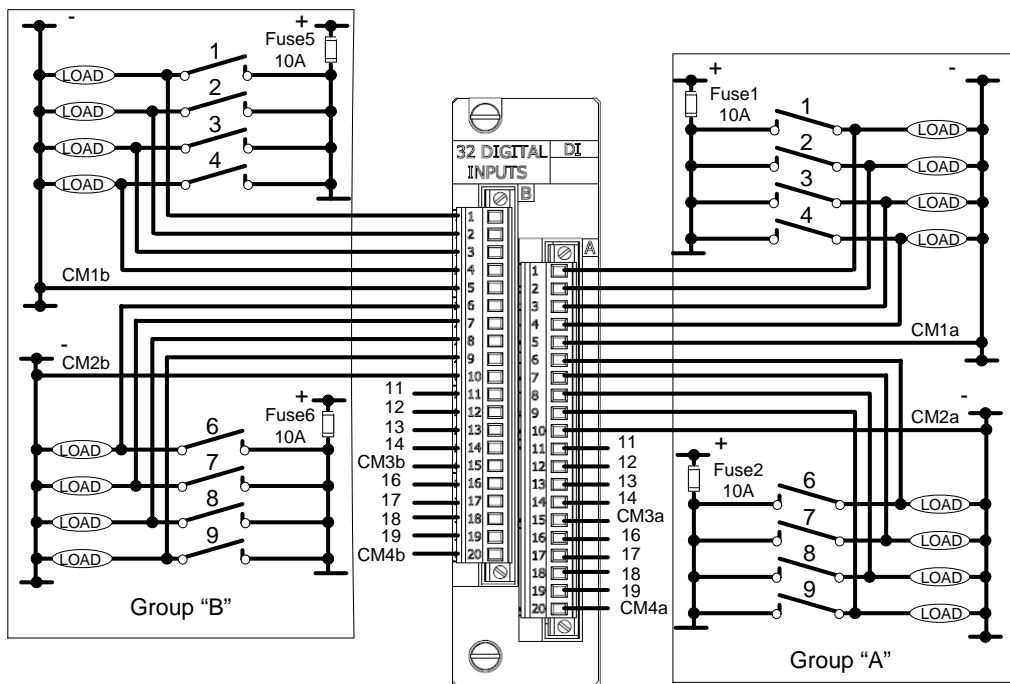
## Wet Contacts

Wet contact options are: 24V, 48V, 125 , 250 VDC (voltage varies according to wet contact option).



02-04025

**Figure 2-12** 16-DI Digital Input Connection for Wet Contacts.



**Figure 2-13** 32-DI Digital Input Connection for Wet Contacts.

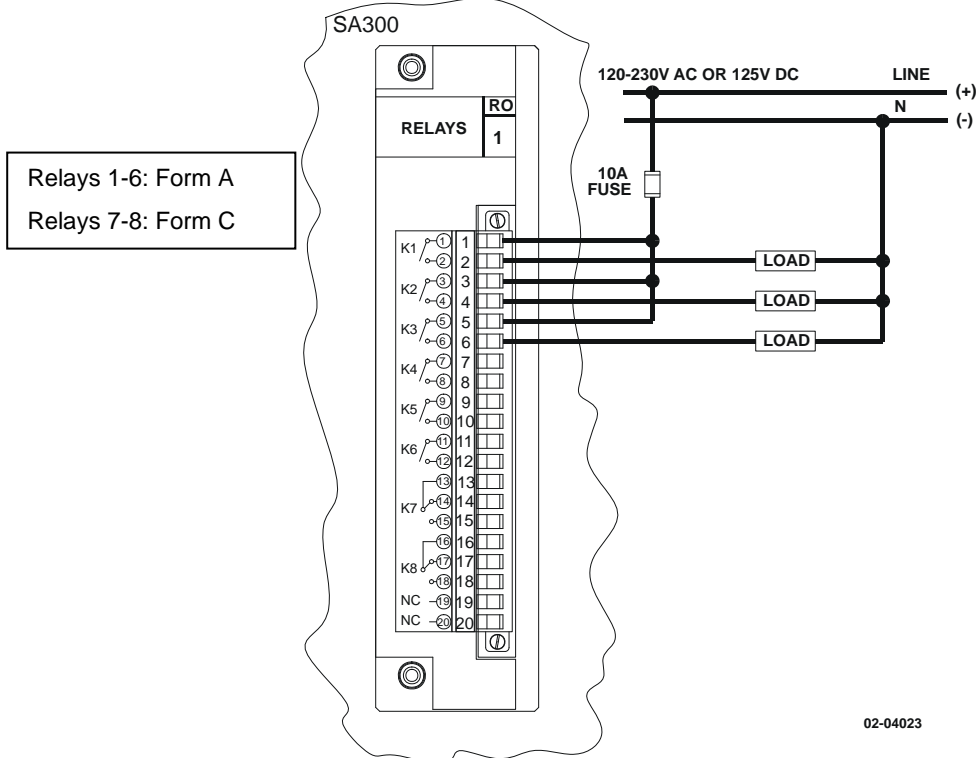


## Relays

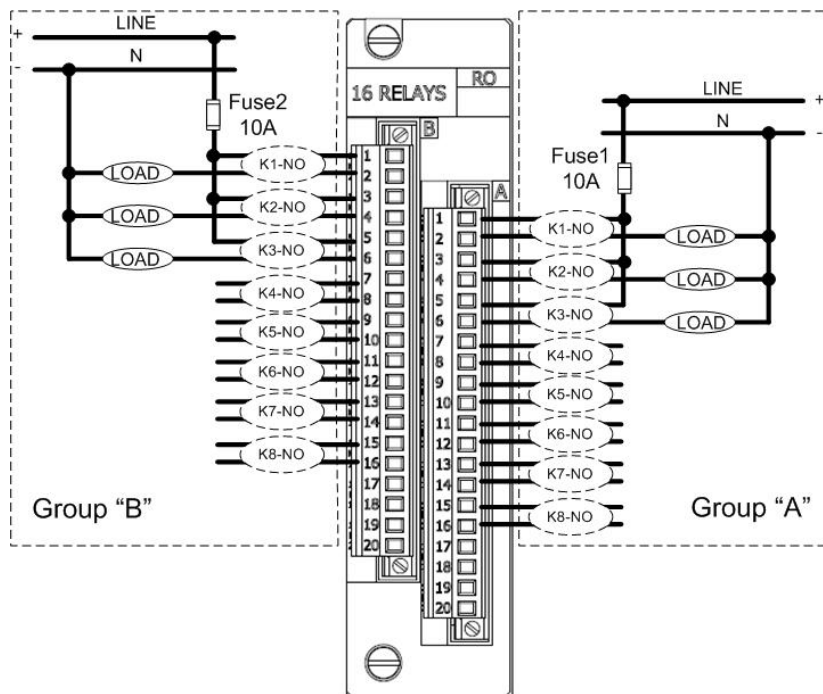
There are two possible variants:

- a) 8 relays in one Relay Output Module.
- b) 8x2 (16) relays in one Relay Output Module.

These output are provided for alarms, remote control or energy pulsing, as shown in *Figure 2-14 and 15*. For ratings, see *Appendix: Technical Specifications*.



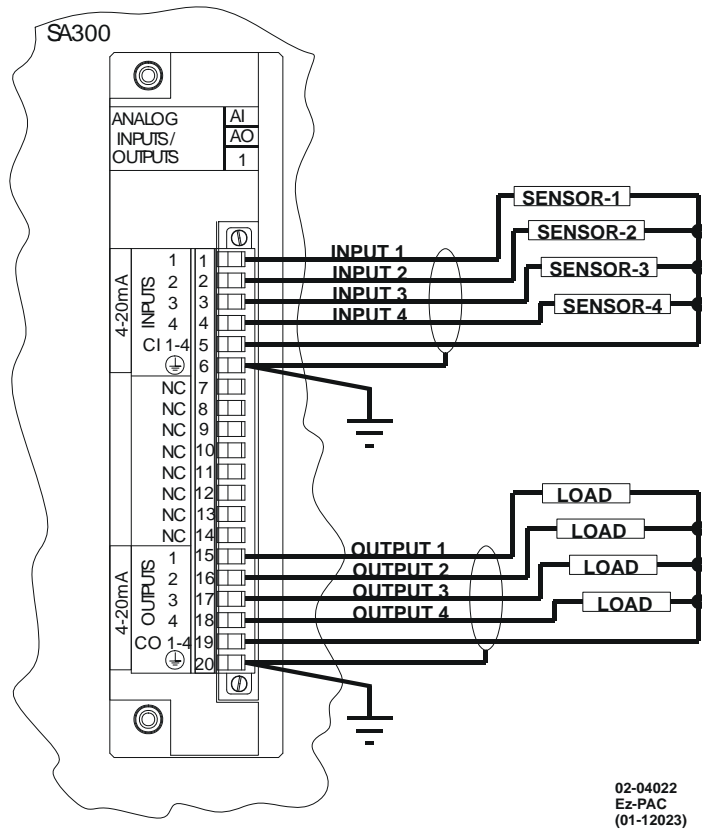
**Figure 2-14** 8-DO Relays Connection



**Figure 2-15** 16-DO Relays Connection.

### 2.2.7 Analog Output

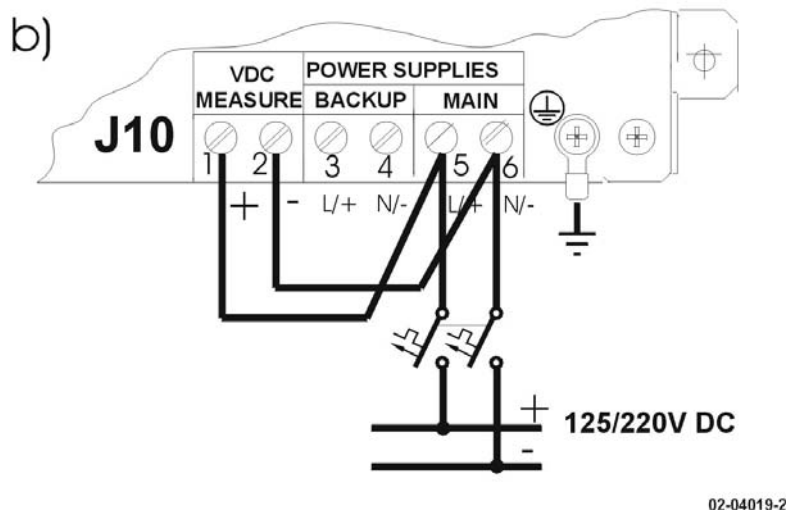
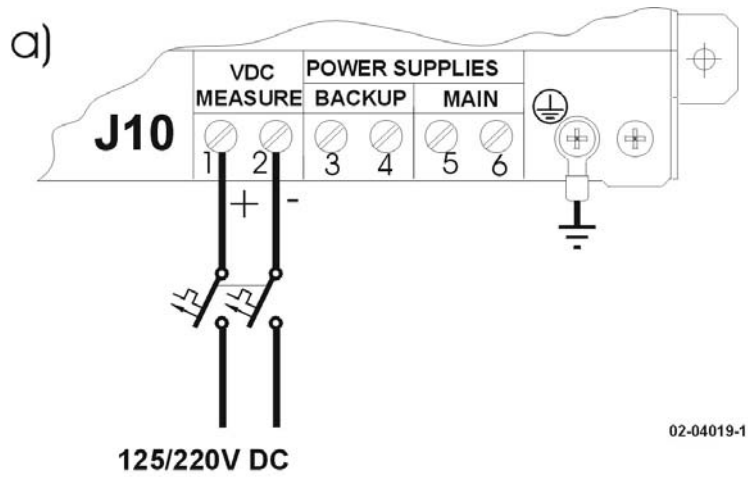
The SA300 provides 4 optically isolated analog inputs and 4 analog outputs with internal power supplies. Current output options are: 0-20 mA and 4-20 mA (current loop load of up to 500 Ohm), 0-1 mA and  $\pm 1$  mA (current loop load of up to 10 kOhm), as shown in *Figure 2-16*.



**Figure 2-16** Analog Output Connection

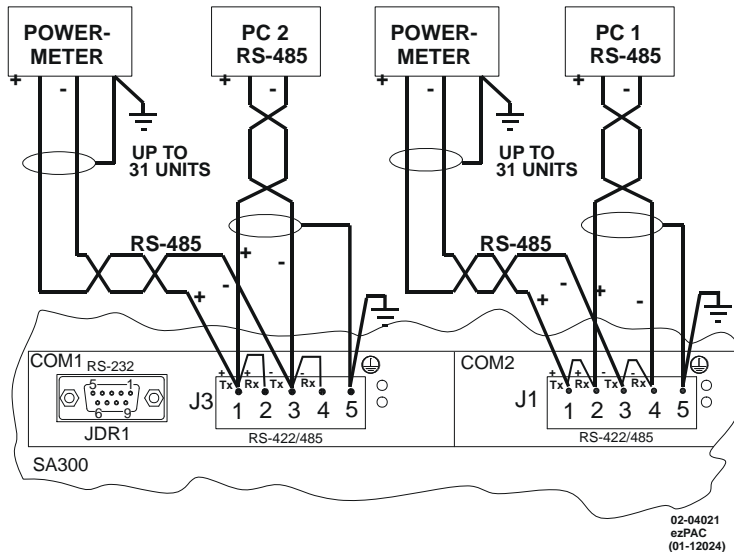
### 2.2.8 DC Voltage Input

SA300 models are provided with one DC voltage input, which can be used for measuring of substation storage battery voltage (see *Figure 2-17a*), or for measuring unit power supply voltage (see *Figure 2-17b*). Copper wiring 1.5-2.5 mm<sup>2</sup> (15 –13 AWG) should be used.



**Figure 2-17 a) and b)** DC Voltage Measurement Input Connection

## 2.2.9 Communications



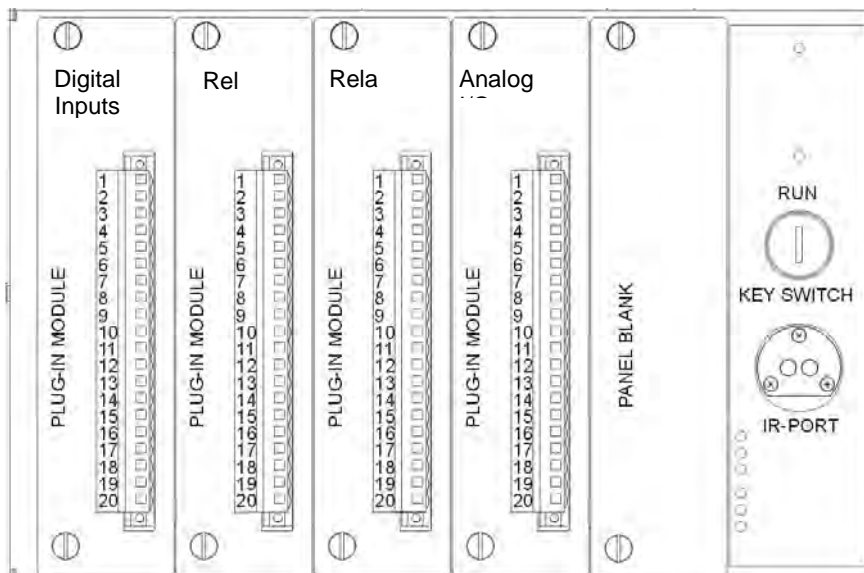
**Figure 2-18** Communication Network Connection – RS-422/RS-485

## 2.3 Location of Modules

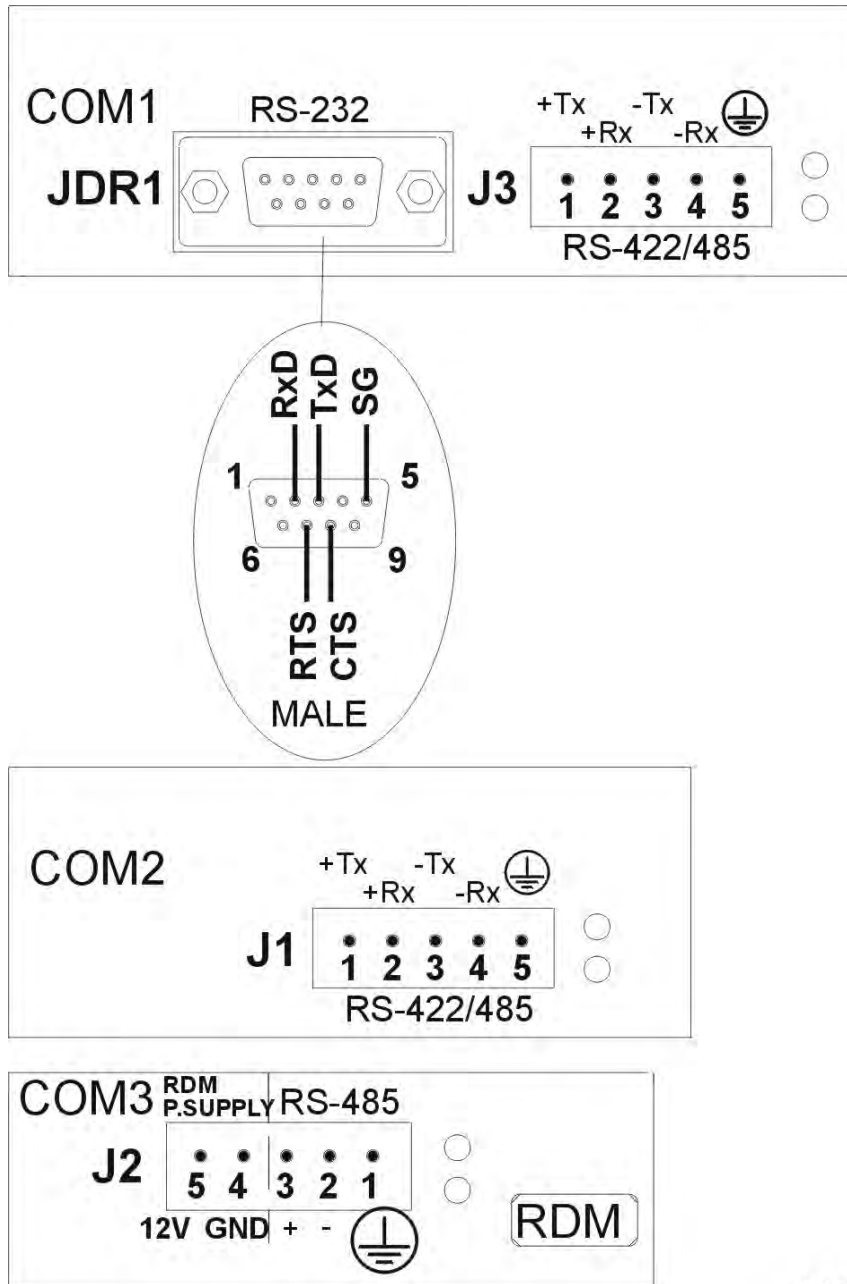
The 5 slots for input/output modules are used as follows:

Slots from left to right: Digital Inputs – Relays – Analog Inputs/Outputs. The standard order is one of each of these modules. If an additional module is ordered, it is placed next to its kind and the subsequent modules are moved to the right.

For example: If an additional Relay module is ordered, the order of the modules is as shown below:



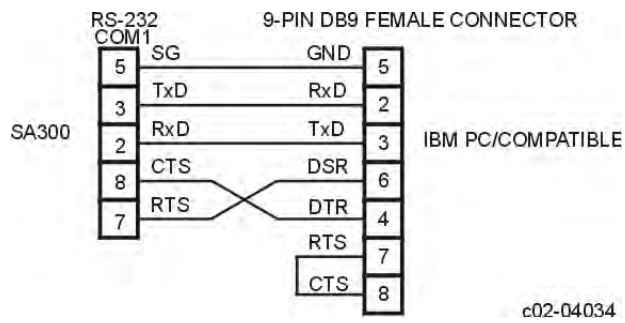
# Chapter 3 Communications



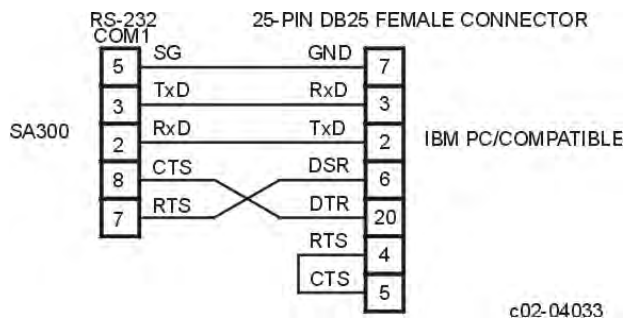
02-04036

Figure 3-1 RS-232/RS-422/RS-485 Terminal Blocks

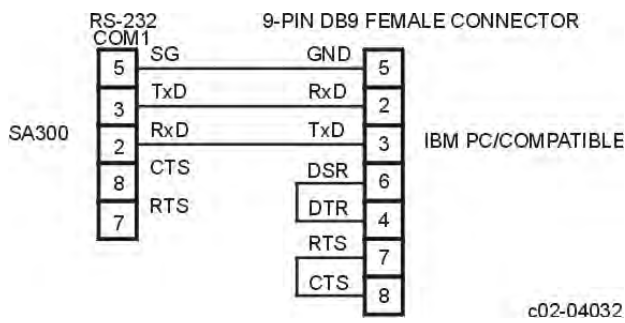
## Computer Connections – RS-232



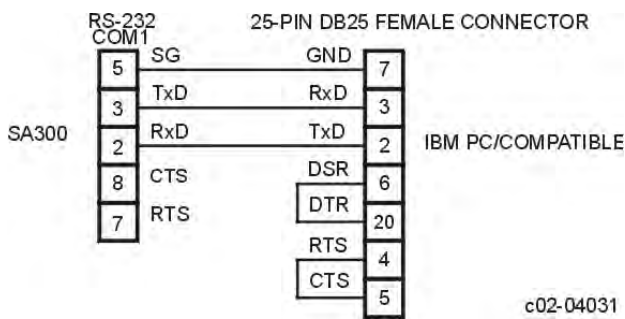
**Figure 3-2** RS-232 Hardware Handshaking Connection , 9-pin



**Figure 3-3** RS-232 Hardware Handshaking Connection , 25-pin

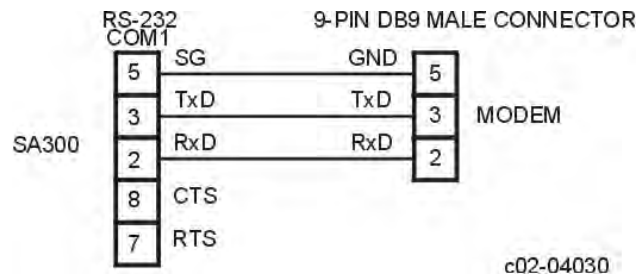


**Figure 3-4** RS-232 Simple 3-wire Connection , 9-pin female

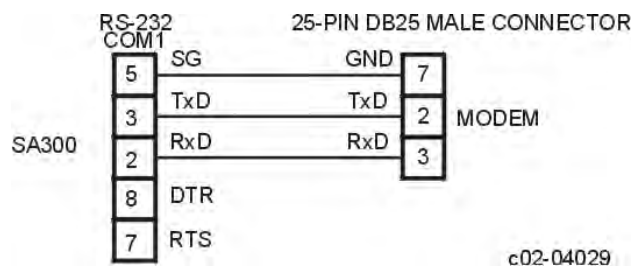


**Figure 3-5** RS-232 Simple 3-wire Connection, 25-pin

## External Modem Connections



**Figure 3-6** RS-232 Simple 3-wire Connection, 9-pin male



**Figure 3-7** RS-232 Simple 3-wire Connection, 25-pin

Initialization String: AT\$0=1&D0&K0&W0

## Computer Connections – RS-422/RS-485

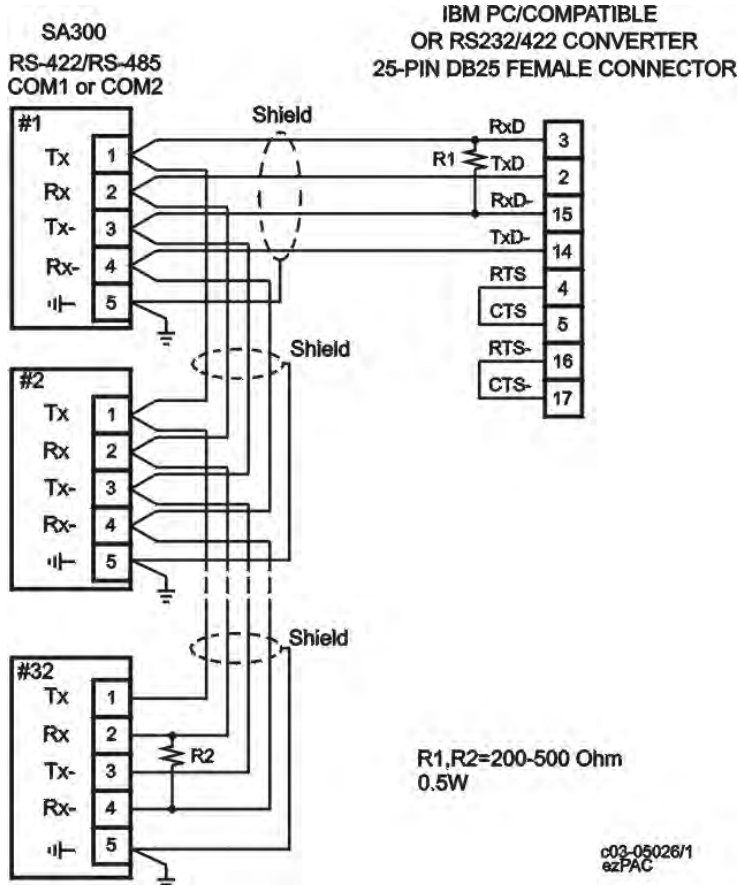


Figure 3-8 RS-422 Multidrop Connection, 25-pin PC Port

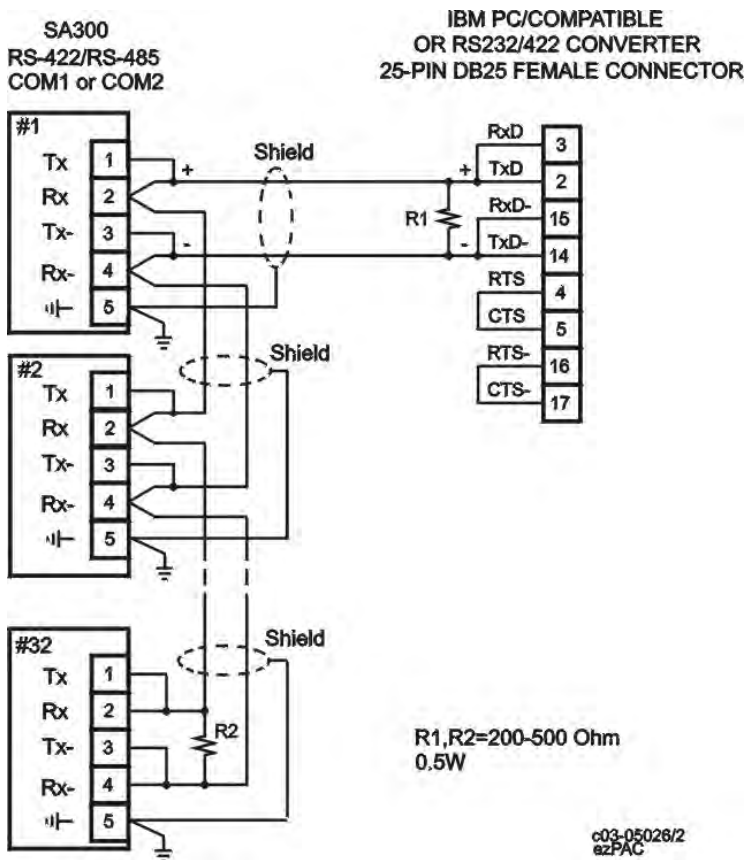


Figure 3-9 RS-485 Multidrop Connection, 25-pin PC Port



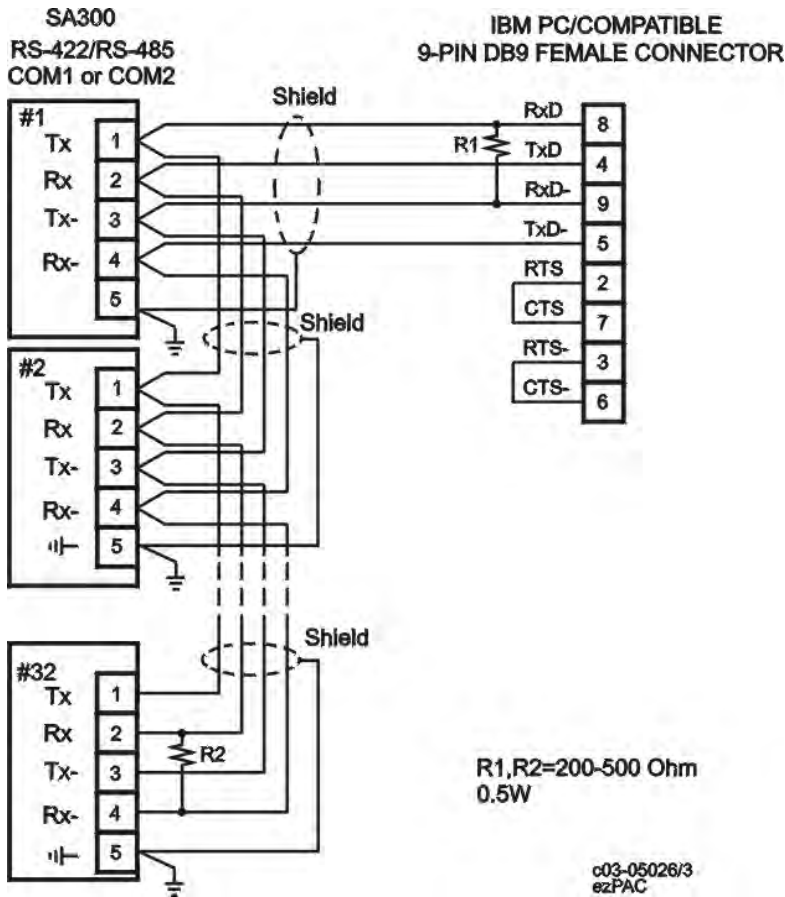


Figure 3-10 RS-422 Multidrop Connection, 9-pin PC Port

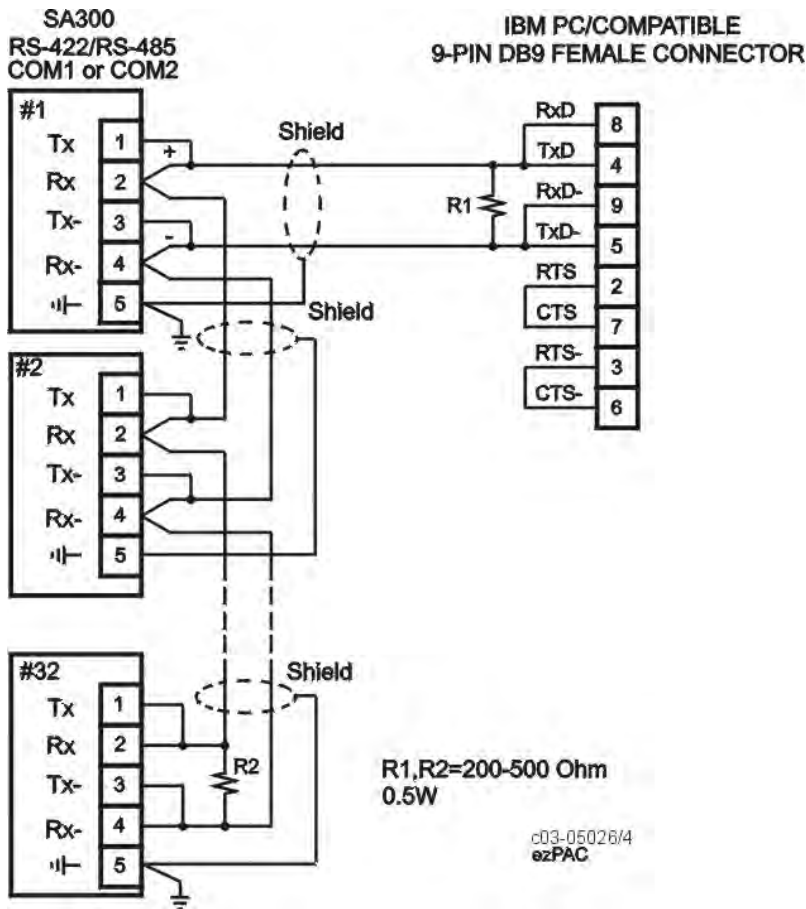
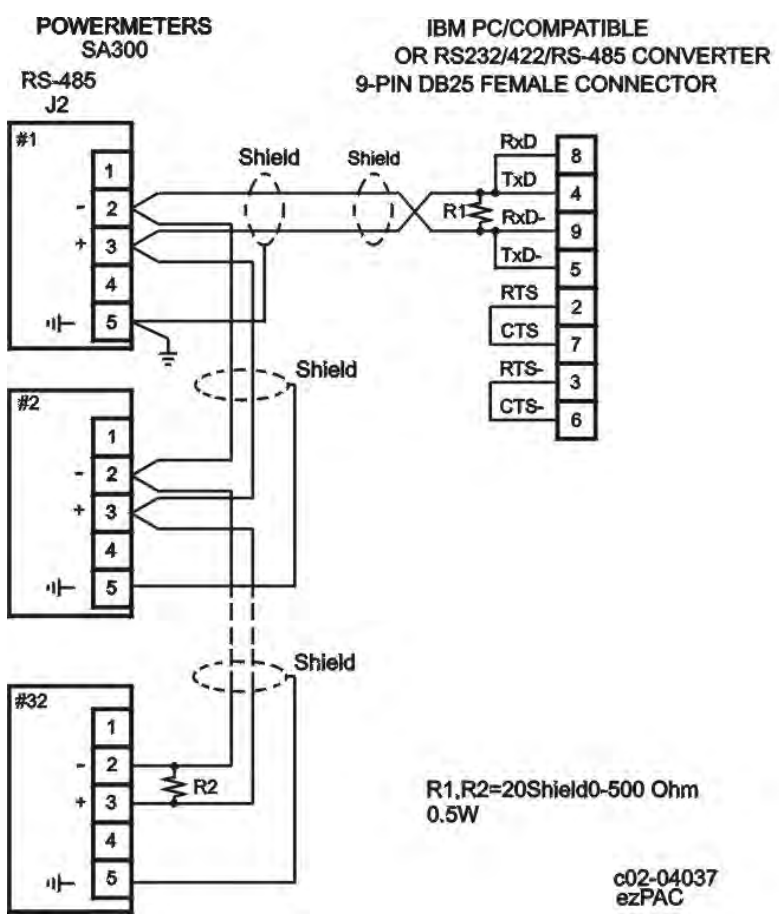
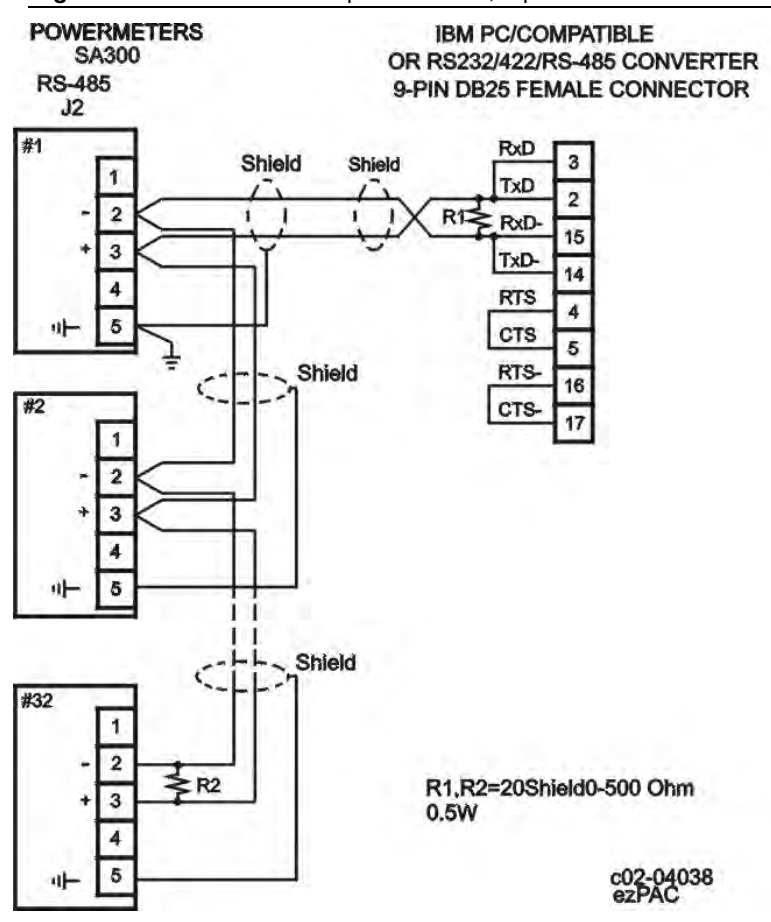


Figure 3-11 RS-485 Multidrop Connection, 9-pin PC Port



**Figure 3-12** RS-485 Multidrop Connection, 9-pin PC Port

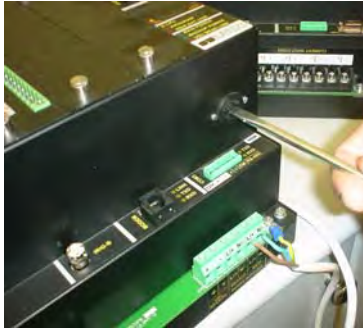


**Figure 3-13** RS-485 Multidrop Connection, 25-pin PC Port

# Chapter 4 Changing the Battery

When the battery level drops below the minimum allowed threshold, the red MEM.BAT.LOW LED on the front of the device is lit up, indicating that the battery should be replaced. Use the following procedure:

1. Use a flat screwdriver to open the battery compartment, turning counter-clockwise.



2. Remove the battery cover and the battery



3. Replace the battery - with the plus towards the outside - and close the compartment.

## IMPORTANT

- 
- Use an AA lithium 3.6 volt battery.
  - In order not to lose data stored in the memory, use PAS to upload data (see SA300 Operation Manual, Chapter 12) to a PC BEFORE changing the battery; OR, make sure you change the battery while the power is ON. If you change the battery while power is off, you will lose all data currently stored in the memory.
-

# Appendix: Technical Specifications

## Environmental Conditions

Operating Temperature: -20°C to 60°C (-4°F to 140°F)  
Storage Temperature: -25°C to 80°C (-13°F to 176°F)  
Humidity: 0 to 95% non-condensing

## Construction

### Overall Dimensions

Length: 284.00 mm (11.181 Inches)  
Width: 255.24 mm (10.05 Inches)  
Depth: 185.00 mm (7.28 Inches)  
Weight: 5.0kg (11.02 Lb)

### Materials

Enclosure: Cold rolled Steel  
Panels I/O: Aluminum  
Face Plates with Graphics: Polycarbonate film  
PCB : FR4 (UL94-V0)  
Terminals: PBT (UL94-V0)  
Connectors-Plug-in type: Polyamide PA6.6 (UL94-V0)  
Packaging Case: Carton and Stratocell (Polyethylene Foam) Brackets  
Labels: Polyester film (UL94-V0)

## Power Supply

Isolation: galvanically isolated  
Option 120/230 VAC-110/220 VDC: Rated input 85-265VAC 50/60 Hz, 88-290VDC, Burden 20W  
12 VDC Option: Rated input 9.6-19 VDC  
24 VDC Option: Rated input 19-37 VDC  
48 VDC Option: Rated input 37- 72 VDC

## Input Ratings

### AC Voltage Inputs: V1, V2, V3, VN

Operating Range: 690VAC line-to-line, 400VAC line-to-neutral  
Direct input and input via PT (up to 828VAC line-to-line, up to 480VAC line-to-neutral)  
Input Impedance: 500 kOhm  
Burden for 400V: < 0.35 VA  
Burden for 120V: < 0.03 VA  
Overvoltage Withstand: 1000VAC continuous, 2500VAC for 1 second  
Galvanic Isolation: 3500V AC  
Wire Size: up to 10 AWG (up to 6 mm<sup>2</sup>)  
Terminals Pitch 9.5 mm

### AC Voltage Inputs: V4, V4N

Operating Range: 400VAC  
Direct input and input via PT (up to 480VAC)  
Input Impedance: 500 kOhm  
Burden for 400V: < 0.35 VA  
Burden for 120V: < 0.03 VA  
Overvoltage Withstand: 1000VAC continuous, 2500VAC for 1 second  
Galvanic Isolation: 3500V AC  
Wire Size: 10 AWG ( up to 6 mm<sup>2</sup>)

Terminals Pitch: 9.5 mm

### **Standard AC Current Inputs: I1, I2, I3, I4**

#### **Input via CT with 5A secondary**

Operating range: continuous 20A RMS (ANSI C12.20) or 10A RMS (IEC687)

Fault Currents: up to 150A RMS (30x)

Burden: < 0.15 VA

Overload Withstand: 20A RMS continuous, 250A for 1 second

Wire Size: 10 AWG (2.5 to 6 mm<sup>2</sup>)

Terminals Pitch: 13 mm

#### **Input via CT with 1A secondary**

Operating Range: continuous 4A RMS (ANSI C12.20) or 2A RMS (IEC687)

Fault Currents: up to 30A RMS

Burden: < 0.02 VA

Overload Withstand: 4A RMS continuous, 50A for 1 second

Wire Size: 10 AWG (2.5 to 6 mm<sup>2</sup>)

Terminals Pitch: 13 mm

### **Optional AC Current Inputs: I5, I6, I7, I8**

#### **Input via CT with 5A secondary**

Operating Range: continuous 20A RMS (ANSI C12.20) or 10A RMS (IEC687)

Burden: < 0.15 VA

Overload Withstand: 20A RMS continuous, 250A for 1 second

Wire Size: 12 AWG (1.5 to 3.5 mm<sup>2</sup>)

Terminals Pitch: 10 mm

#### **Input via CT with 1A secondary**

Operating Range: continuous 4A RMS (ANSI C12.20) or 2A RMS (IEC687)

Burden: < 0.02 VA

Overload Withstand: 4A RMS continuous, 50A for 1 second

Wire Size: 12 AWG (1.5 to 3.5 mm<sup>2</sup>)

Terminals Pitch: 10 mm

### **VDC Voltage Input**

Operating Range: 2-290 VDC

Burden: < 0.2 W

Accuracy: ±0.5%

Galvanic Isolation: 2500V DC

Wire Size: 10 AWG (up to 6 mm<sup>2</sup>)

Terminals Pitch: 9.5 mm

Scan time: 1/2 cycle

## **Plug-In I/O Ratings**

### **Digital Inputs (up to 3 I/O Modules)**

Scan time: 1 ms @ 60Hz, 1.25 ms @ 50Hz.

#### **16-DI optically isolated, dry contact sensing (voltage-free):**

Internal power supply 24 VDC

Sensitivity: open @ input resistance >100kOhm, closed @ input resistance <1kOhm

Wire Size: 12 AWG (up to 2.5 mm<sup>2</sup>)

Terminals Pitch: 5 mm

#### **16-DI optically isolated, wet contact sensing:**

External Power Supply: 24 VDC

Sensitivity: open @ voltage < 8 volts, closed @ voltage > 17 volts

Wire Size: 12 AWG (up to 2.5 mm<sup>2</sup>)

Terminals Pitch: 5 mm

**16-DI optically isolated, wet contact sensing:**

External Power Supply: 48 VDC

Sensitivity: open @ voltage < 14.4 volts, closed @ voltage > 33 volts

Wire Size: 12 AWG (up to 2.5 mm<sup>2</sup>)

Terminals Pitch: 5 mm

**16-DI optically isolated, wet contact sensing:**

External Power Supply: 125 VDC

Sensitivity: open @ voltage < 37 volts, closed @ voltage > 88 volts

Wire Size: 12 AWG (up to 2.5 mm<sup>2</sup>)

Terminals Pitch: 5 mm

**16-DI optically isolated, wet contact sensing:**

External Power Supply: 250 VDC

Sensitivity: open @ voltage < 75 volts, closed @ voltage > 175 volts

Wire Size: 12 AWG (up to 2.5 mm<sup>2</sup>)

Terminals Pitch: 5 mm

**32-DI optically isolated, (4x8 group), dry contact sensing (voltage-free):**

Internal power supply 24 VDC

Sensitivity: open @ input resistance > 16kOhm, closed @ input resistance < 10kOhm

Wire Size: 12 AWG (up to 2.5 mm<sup>2</sup>)

Terminals Pitch: 5 mm

**32-DI optically isolated, (4x8 group), wet contact sensing:**

External Power Supply: 24 VDC

Wire Size: 12 AWG (up to 2.5 mm<sup>2</sup>)

Terminals Pitch: 5 mm

**32-DI optically isolated, (4x8 group), wet contact sensing:**

External Power Supply: 48 VDC

Wire Size: 12 AWG (up to 2.5 mm<sup>2</sup>)

Terminals Pitch: 5 mm

**32-DI optically isolated, (4x8 group), wet contact sensing:**

External Power Supply: 125 VDC (100-150VDC)

Wire Size: 12 AWG (up to 2.5 mm<sup>2</sup>)

Terminals Pitch: 5 mm

**32-DI optically isolated, (4x8 group), wet contact sensing:**

External Power Supply: 250 VDC (180-250VDC)

Wire Size: 12 AWG (up to 2.5 mm<sup>2</sup>)

Terminals Pitch: 5 mm

**Relay Outputs (up to 4 I/O Modules)****8-DO:**

6 relays rated at 10A/250 VAC; 5A/125 VDC, (SPST Form A)

2 relays rated at 8A/250 VAC; 5A/30 VDC, (SPDT Form C)

Wire Size: 12 AWG (up to 2.5 mm<sup>2</sup>)

Terminals Pitch: 5 mm

Update time: 1/2 cycle

**16-DO:**

2x8 relays rated at 8A/250 VAC; 0.25A/250 VDC, (SPST Form A)

Wire Size: 12 AWG (up to 2.5 mm<sup>2</sup>)  
Terminals Pitch: 5 mm  
Update time: 1/2 cycle

### **Analog Inputs/Outputs (up to 3 I/O Modules)**

#### **4 Analog Inputs:**

Ranges (upon order):

±1 mA (×200% overload)

0-20 mA

4-20 mA

0-1 mA (×200% overload)

Accuracy: 0.5% FS

Scan time: 2 cycles

#### **4 Analog Outputs:**

Ranges (upon order):

±1 mA, maximum load 10 kΩ (100% overload)

0-20 mA, maximum load 510 Ω

4-20 mA, maximum load 510 Ω

0-1 mA, maximum load 10 k Ω (×200% overload)

Accuracy: 0.5% FS

Wire Size: 12 AWG (up to 2.5 mm<sup>2</sup>)

Terminals Pitch: 5 mm

Update time: 2 cycles

## **Communication Ports**

### **COM1**

Serial EIA RS-232 optically isolated port

Connector Type: DB9 male.

Serial EIA RS-422/RS-485 optically isolated port

Connector Type: removable, captured-wire, 5 terminals.

Wire Size: up to 12 AWG (up to 2.5 mm<sup>2</sup>).

Baud Rate: up to 115,200 bps.

Supported Protocols: Modbus RTU/ASCII, DNP 3.0.

### **COM2**

Serial EIA RS-422/RS-485 optically isolated port

Connector type: removable, captured-wire, 5 terminals.

Wire Size: up to 12 AWG (up to 2.5 mm<sup>2</sup>).

Baud Rate: up to 115,200 bps.

Supported Protocols: Modbus RTU/ASCII, DNP 3.0.

### **COM3**

Serial EIA RS-485 optically isolated port with 12VDC supply voltage for the RDM.

Connector Type: removable, captured-wire, 5 terminals.

Wire Size: up to 12 AWG (up to 2.5 mm<sup>2</sup>).

Baud Rate: up to 115,200 bps.

Supported Protocols: Modbus RTU/ASCII, DNP 3.0.

### **USB Port**

Non-isolated USB 1.1 port.

Wire Type: standard USB cable, max. length 2 meters.

Supported protocols: Modbus RTU.

### **Ethernet Port**

Transformer-isolated 10Base-T port.

Connector Type: RJ45 modular.

Supported Protocols: Modbus TCP (Port 502), DNP 3.0/TCP (Port 20000). IEC61850 (including GOOSE & MMS)

SNTP Time synchronization.

Number of simultaneous connections (sockets): 5.

### **Modem Port**

Transformer-isolated internal 56K modem.

Connector Type: RJ11.

Supported Protocols: Modbus RTU/ASCII, DNP 3.0.

### **Infrared Port**

Optional optical IEC/ANSII head.

Baud Rate: up to 115,200 bps.

Supported Protocols: Modbus RTU/ASCII, DNP 3.0.

## **Real-time Clock**

Accuracy: maximum error 15 seconds per month @ 25°C

## **IRIG-B Port**

Optically isolated IRIG-B port.

Time code signal: unmodulated (pulse-width coded).

Level: unbalanced 5V.

Connector Type: BNC.

Recommended cable: 51Ohm low loss - RG58A/U (Belden 8219 or equivalent), TNC connector.

Recommended GPS time code generator: Masterclock GPS-200A.

## **Log Memory**

Standard onboard memory: 4 Mbytes.

Plug-in expansion memory module: 64/128 Mbytes

## **Remote Display Module**

Display: high-brightness seven-segment digital LEDs, three 6-digit windows

Keypad: 6 push buttons

Communication: EIA RS-485 port with 12V supply voltage

Connector Type: captured-wire, 5 terminals

Wires Size: up to 12 AWG (up to 2.5 mm<sup>2</sup>)

Distance: up to 1200m (4000 feet)



## Standards Compliance

Directive complied with: EMC: 89/336/EEC as amended by 92/31/EEC and 93/68/EEC

LVD: 72/23/EEC as amended by 93/68/EEC and 93/465/EEC

Harmonized standards to which conformity is declared: EN55011:1991; EN50082-1:1992; EN61010-1:1993; A2/1995

ANSI C37.90.1 1989 Surge Withstand Capability (SWC)

EN50081-2 Generic Emission Standard - Industrial Environment

EN50082-2 Generic Immunity Standard - Industrial Environment

EN55022: 1994 Class A

EN61000-4-2

ENV50140: 1983

ENV50204: 1995 (900MHz)

ENV50141: 1993

EN61000-4-4:1995

EN61000-4-8: 1993

## Measurement Specifications

Parameter	Full Scale @ Input Range	Accuracy			Range
		% Reading	% FS	Conditions	
Voltage V1-V4	120VxPT @ 120V 400VxPT @ 690V	0.2	0.01	10% to 120% FS	0 to 999,000 V
<b>SA310, SA320</b> Line current I1-I4	CT	0.2 0.2	0.01	ANSI C12.20: 1% - 120% FS 120% - 400% FS IEC 687: 1% - 200% FS	0 to 9999 A
Fault current I1-I4	CT	2.0		400% - 3000% FS	0 to 9999 A
<b>SA330</b> Line current I5-I8	CT	0.2 0.2	0.01	ANSI C12.20: 1% - 120% FS 120% - 400% FS IEC 687: 1% - 200% FS	0 to 9999 A
DC Voltage	125V/220V		0.3	10% - 120%FS	0 to 290VDC
Active power	0.36xPTxCT @ 120V 1.2xPTxCT @ 690V	0.2	0.002 0.002	PF  ≥ 0.5 and ①	-2,000,000 to +2,000,000 kW
Reactive power	0.36xPTxCT @ 120V 1.2xPTxCT @ 690V	0.3	0.002 0.002	PF  ≤ 0.9 and ①	-2,000,000 to +2,000,000 kvar
Apparent power	0.36xPTxCT @ 120V 1.2xPTxCT @ 690V	0.2	0.002 0.002	PF  ≥ 0.5 and ①	0 to 2,000,000 kVA
Power factor	1.000		0.35	PF  ≥ 0.5, I ≥ 2% FSI	-0.999 to +1.000
Frequency		0.02			40.00 Hz to 70.00 Hz
Total Harmonic Distortion, THD V (I), %V <sub>f</sub> (%I <sub>f</sub> )	999.9	1.5	0.2	THD ≥ 1% FS, V (I) ≥ 10% FSV (FSI)	0 to 999.9
Total Demand Distortion, TDD, %	100		1.5	TDD ≥ 1% FS, I ≥ 10% FSI	0 to 100
Active energy Import & Export		Class 0.2 ANSI C12.20-1998 Current class 20 Class 0.2S (IEC 687-1992-6)			0 to 999,999.999 MWh
Reactive energy Import & Export		Class 0.2 under conditions as per ANSI C12.20-1998 Class 0.2 under conditions as per IEC 687-1992-6			0 to 999,999.999 Mvarh
Apparent energy		Class 0.2 under conditions as per ANSI C12.20-1998 Class 0.2 under conditions as per IEC 687-1992-6			0 to 999,999.999 MVAh
Volt-hours		Class 0.2		20% - 120% FS	0 to 999,999.999 kWh
Ampere-hours		Class 0.2		10% - 200% FS	0 to 999,999.999 kAh
Symmetrical components	Voltage FS Current FS Current FS	1 1 3		10% - 120% FS 10% - 200% FS 200% - 3000%FS	
Phasor angles		1 degree			

Key: PT - external potential transformer ratio  
current FS

① @ 80% to 120% of voltage FS and 1% to 200% of

CT - primary current rating of external current transformer

FSV - voltage full scale; FSI - current full scale

V<sub>f</sub> - fundamental voltage; I<sub>f</sub> - fundamental current

**Notes**

1. Accuracy is expressed as  $\pm$  (percentage of reading + percentage of full scale)  $\pm$  1 digit. This does not include inaccuracies introduced by the user's potential and current transformers. Accuracy calculated at 1 second average.
2. Specifications assume: voltage and current waveforms with THD  $\leq$  5% for kvar, kVA and PF; reference operating temperature: 20°C - 26°C.
3. Measurement error is typically less than the maximum error indicated here.