

expertmeter™

EM920

SOCKET METER

 **SATEC**
Powerful Solutions



HIGH PERFORMANCE REVENUE SOCKET METER

CUTTING EDGE POWER QUALITY ANALYZER

FAST TRANSIENT & FAULT RECORDER

expertmeter™ EM920

Advanced Metering Infrastructure (AMI) has reached new heights with SATEC's latest introduction in energy and power quality measurements for smart grid deployments.

The SATEC Model EM920 eXpertmeter™ is an advanced energy analyzer in a socket meter with precise measurement and expansion capabilities.

The EM920's unique "Add-On" modularity is the key to its remarkable versatility and unprecedented effort to add intelligence, control and communications to electrical metering. SATEC's "Add-On" module concept allows you to configure the meter to your changing needs, thus saving valuable time in the field or future costly replacements. Technological advancements

revitalize legacy applications to rapidly and cost-efficiently respond to changing market conditions.

The Model EM920 eXpertmeter™ is an advanced energy meter that exceeds Class 0.2S class revenue billing requirement. It provides long term memory for load & trend profiles, and includes advanced power quality analysis to detect and record waveform events and fault currents harmful to power systems.

The Model EM920 eXpertmeter™ provides a real-time view into a greater volume of data than a standard energy meter, leading to faster analysis and better decision-making all around. Customers benefit from better access to information—while providing better service that costs less.



Applications

The EM920 eXpertmeter™ Series is used in electric utility inter-ties, any electrical substation where precise information is required for planning purposes, and monitoring primary customers on the service entrance to provide a higher service in quality of power.

- Install at legacy substations where little to no information is currently provided. Just replace existing socket meter and instantly provide information previously unattainable.
- Long term monitoring and storing capabilities allow for many months of information storage. Record Time Of Use (TOU), load profile, Min/Max, custom reports etc.—essential information used for planning and maintenance engineers.
- Multiple simultaneous communications allow communication via MODBUS, DNP3.0, and MV90 while retrieving power quality events such as SAG/SWELL and transient detections.
- View Harmonic conditions locally to determine the cause of problems by utilizing its unique "Directional" Harmonics Power flow.
- View real time Oscillography and determine quality of power
- Multiple levels of password protection to prevent unauthorized access
- Time synchronization (IRIG-B, Ethernet SNTP) with 1 mSec accuracy

Features

- **Modularity: Add-On module support** to configure and change with your growing needs, instead of requiring complete assemblies that can only be changed at the factory
- **Add on I/O slots.** Add inputs to count other pulses or add outputs to generate energy pulse
- **Real Time Oscillography.** View quality of power (waveform) in real time
- Internal memory for long term data storage—16 MB
- Optional Remote Display Module (RDM) LED front panel display
- True Power Quality EN 50160 Standard
- Precise measurement 0.05% revenue grade accuracy
- Advanced Power Quality waveform recording (4 waveform recorders)
- Selectable 32-1024 samples per cycle
- High Speed Transient detection as little as 17 μ s @ 60Hz
- Exceeds EN 50160 Standards
- Exceeds IEC 61000-4-7; IEC 61000-4-15 and IEC 61000-30
- ITI (CBEMA) curves
- Transformer Line/Loss compensation and up to 8 points Transformer correction (VT, CT)

METER SETUP	
Wiring Mode	4LN3
PT Ratio	1.0
CT Primary	5000 A
Nom. Voltage, L-L	120 V
Nom. Frequency	60 Hz
Power Dmd Period	1x15 min
Volt Dmd Period	900 s
Amp. Dmd Period	900 s
03/03/10 15:42:25 NORM T1 ABC ▶ 1/1 10	

DEVICE CONFIGURATION

- Performance resolution quality graphical screen
- Easy interface with any existing SCADA or EMS system
- Rigid design for use in harsh environments
- Anti-tampering and self test functions
- Standard USB, RS485 and IR port
- MODBUS, DNP3.0 and MV90 compatible
- Time synchronization—IRIG-B or Ethernet (SNTP)

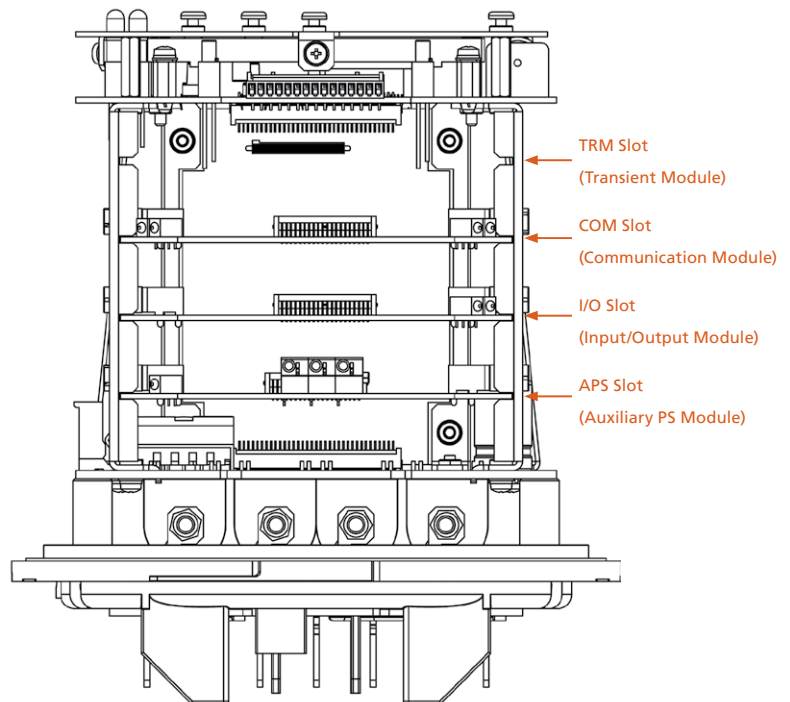
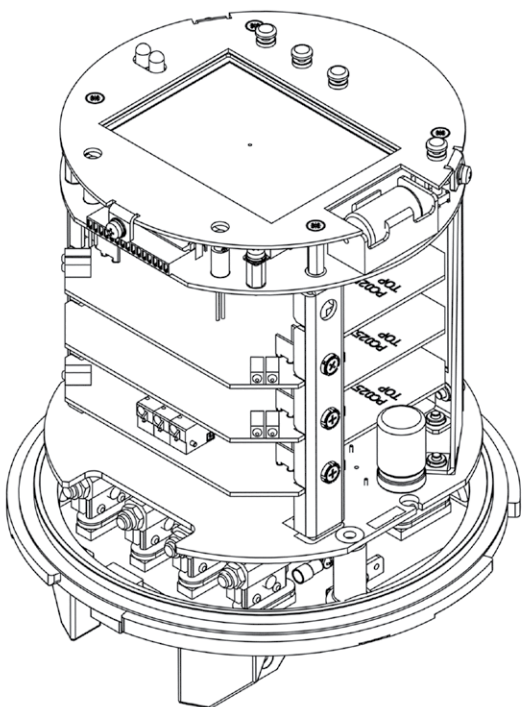

High Performance Revenue Meter

The EM920 is a high precision, multi-purpose 4 quadrant meter used for active, reactive, and apparent energy / demand measurement and recording. The meter is ideal for grid applications in generation, transmission and distribution utilities. Designed for major industrial and commercial consumers as well. Accuracy class 0.2S approved according to ANSI C12.20 class 10/20 and to IEC 62053-22 class 0.2S, and designed according to even more rigorous SATEC standards.

The meter delivers precision, reliability and long-term stability. An all in one meter, the EM920 is the answer to Precise metering of large energy quantities. The EM920 provides Time Of Use (TOU) tariffs to meet any billing requirements (8 tariffs, 4 seasons). The instrument also provides multi-functional three phase power metering with voltage, current (including measured neutral current), power, energy, power factor, frequency, voltage/current unbalance, load profile, and other measurements on-board. More than 100 parameters can be logged with real time stamps.

The EM920 is equipped with high resolution 4" LCD display operating in wide range temperature, offering Real Time measurements, waveforms, Phasor and Harmonics spectrum display.

The EM920 is equipped with anti-vandalism and anti-tampering features. All necessary communication applications are covered

by a modular architecture. This modularity also offers a full freedom of choice for deployment of new technologies. The device supports multiple communication protocols.



- Meets 0.1% Revenue Accuracy (tested to 0.05%)
- Active energy: class 0.2S precision ANSI C12.20 class 10/20
- Advanced Time Of Use (TOU) tariffs to meet any billing requirements (8 tariffs, 4 seasons)
- Data trend recorder and load profile
- Anti-vandalism and anti-tampering features
- Transformer/Line Compensation (TLC) and PT/CT errors correction (up to 8 points)
- Built-in self accuracy test
- Energy and power demand meter
- Block and sliding demands
- Accumulation of energy pulses from external watt-meters

- High precision 3-phase power meter
 - Voltage
 - Current
 - Power
 - Power factor
 - Voltage/current unbalance
 - Neutral current
 - Energy
 - Frequency
 - Load profile

High Performance Revenue Meter

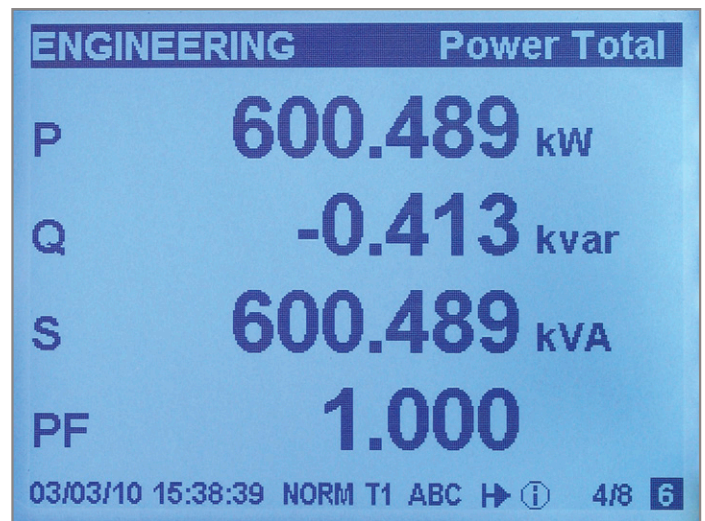
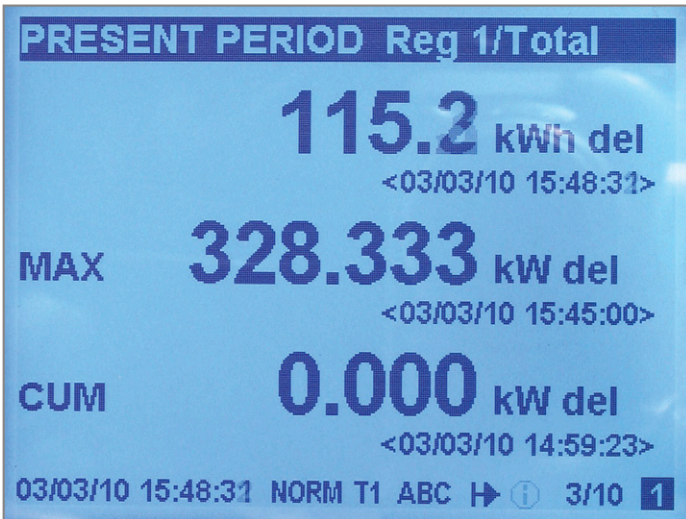

POWER

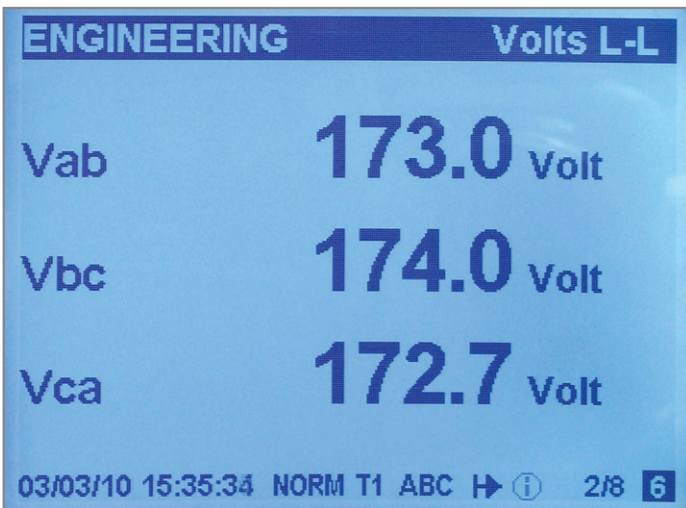

VOLTAGE

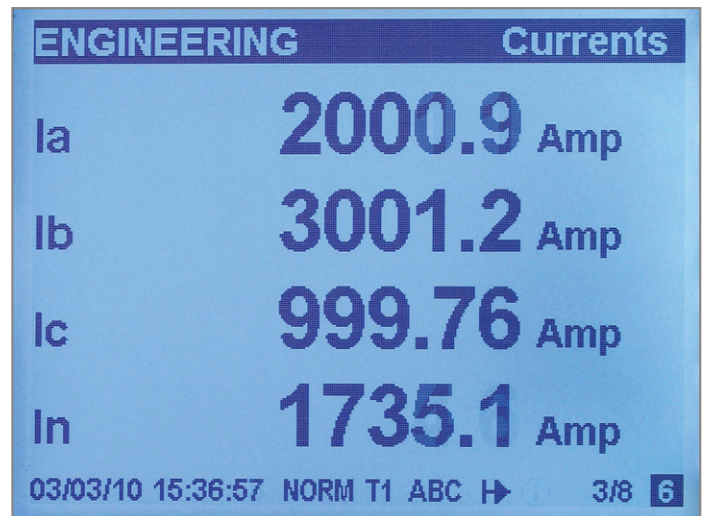

CURRENT

Power Quality Analyzer

Cutting Edge Power Quality Analyzer & Fault Recorder

The EM920 is among the most advanced power quality analyzer and recorder on the market. The instrument is a product of SATEC's 20 years of experience in the creation of power quality instruments. The EM920 is designed to fully comply with the most demanding industry standard, IEC 61000-4-30 Class A. It provides power quality reports and statistics according to EN 50160, complimented by comprehensive power quality event/

data log with waveforms (3 voltage and 4 current inputs for waveform recording) available for detailed Power Quality event analysis. The individual harmonics and inter-harmonics are analyzed according to IEC 61000-4-7. The instrument also supports directional power harmonics analysis. The flicker is measured and analyzed according to IEC 61000-4-15.

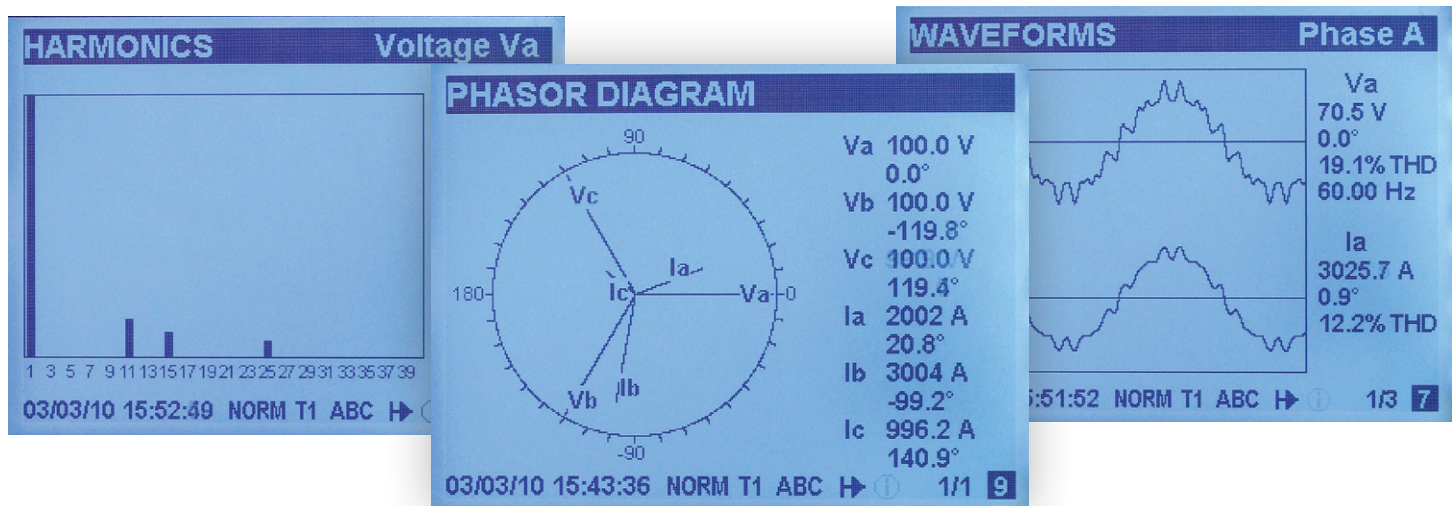

- Power quality analysis and reading
- Sags/swells (dips/overvoltages), interruptions, frequency variations
 - Flicker, voltage unbalance, harmonic and interharmonic voltages with high resolution
 - Programmable thresholds and hysteresis
- Built-in EN 50160 power quality statistics & reports
- Auxiliary power supply for recording major dips & interruptions
- Harmonics & Inter-harmonics according to IEC 61000-4-7
- Directional power harmonics and power factor phasors
- Voltage and current THD components
- Harmonic energies to determine quality of power received or delivered
- Symmetrical components
- Flicker measurement according to IEC 61000-4-15
- Waveform recording
 - Selectable sampling rate up to 1024 samples/cycle
 - Settable up to 20 cycles of pre-fault and any length of post fault cycles
- Power quality event recorder as per EN 50160.
- Event recorder for logging internal diagnostic events, control events and I/O operations

Power Quality Events Via PAS Software

DIRECTIONAL HARMONICS



VOLTAGE DIP

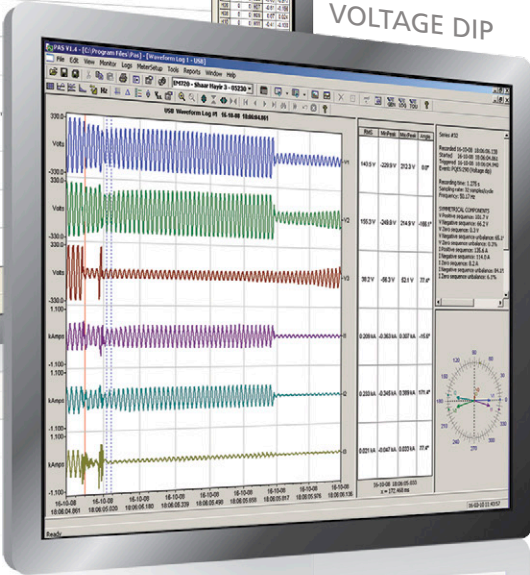

VOLTAGE INTERRUPTION

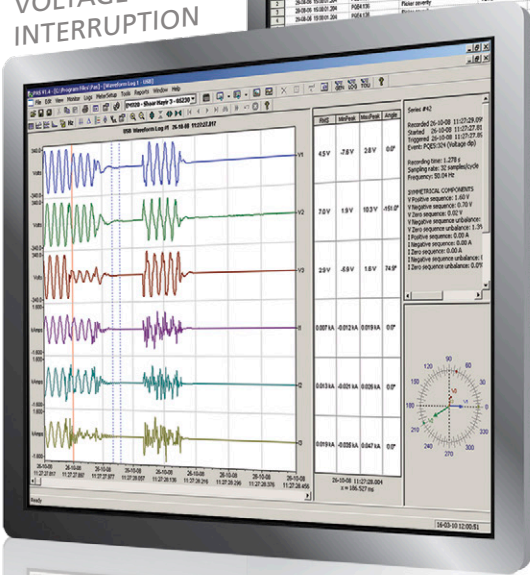

PQ LOG

Time	Phase	Event	Duration
11:00:00	V1	Voltage Dip	0.05
11:00:05	V2	Voltage Dip	0.05
11:00:10	V3	Voltage Dip	0.05
11:00:15	V1	Voltage Interruption	0.10
11:00:20	V2	Voltage Interruption	0.10
11:00:25	V3	Voltage Interruption	0.10

CBEMA CURVE

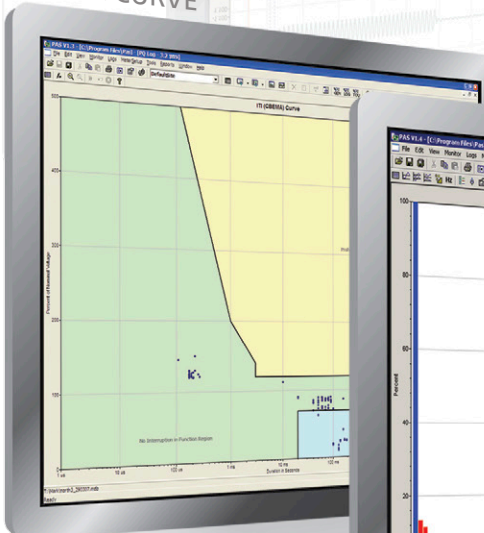

SPECTRUM GRAPH & TABLE

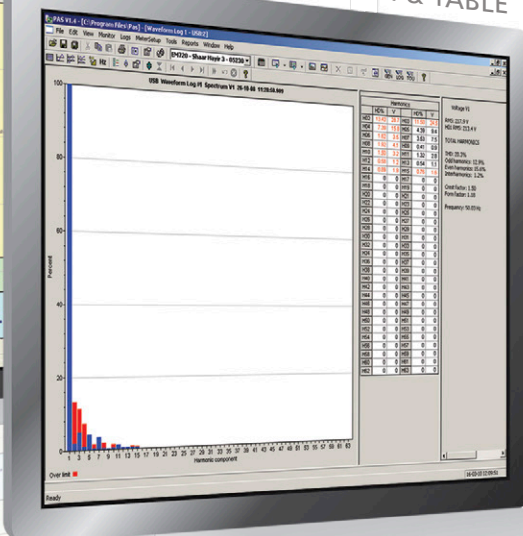

EN 50160 COMPLIANCE REPORT

Item	To	Parameter	Compliance	Min V1/F1	Max V2/F2	Min V3/F3	Standard
1	20-100	Voltage Variations	OK	200	200	200	OK
2	20-100	Voltage Imbalance	OK	0.5	0.5	0.5	OK

Fault & Transient Recorder

The EM920 provides state-of-the-art fast transient recording capability. Transient pulses as short as 17 microseconds can be reliably recorded and analyzed. The EM920 can record such short pulses by a separate electronic channel with a sampling rate of 1024 samples/cycle. The transient amplitude is recorded relative to the ground in accordance with the strict definitions of power quality standards (EN 50160). The instrument can measure transient pulses with an amplitude of up to 2 kV

(withstands up to 6 kV). Four voltage waveforms (3 phases and neutral relative to the ground) are recorded at 1024 samples/cycle to complement the waveforms recorded by the power quality channel.

The fault recorder provides 4 measured and recorded currents (including measured neutral current) up to 50A ($10 I_n$). The event log is complemented by a fault log and full length waveform recording.

SHORT TRANSIENT EVENTS

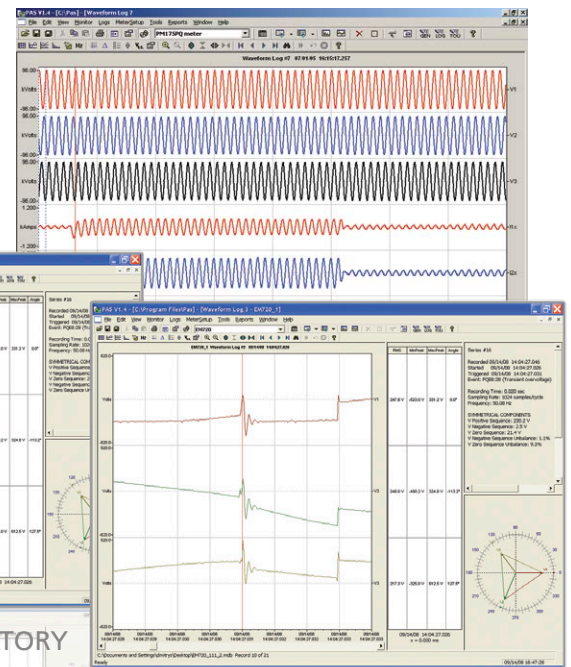
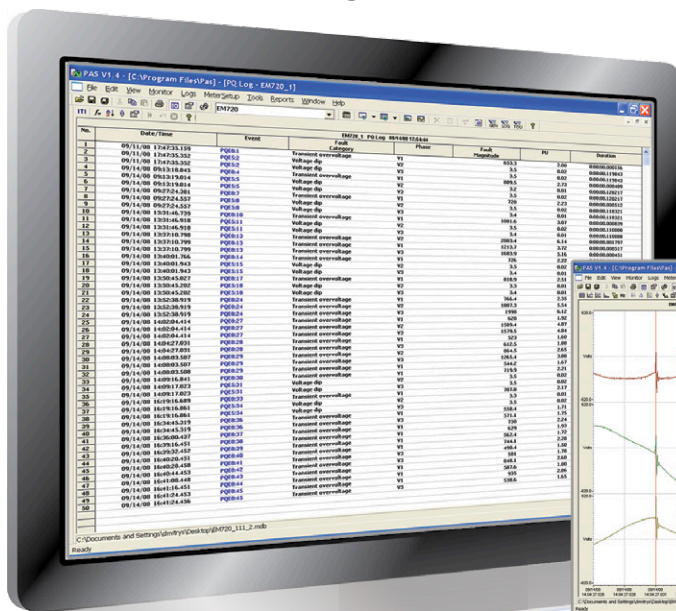

OSCILLATORY

- Reliable recording of short transients—20μs at 50Hz (17μs at 60Hz)
- Measures up to 2kV impulses. Withstands up to 6kV
- 4 fast waveform recorders: Sampling rate of up to 1024 samples per cycle, 3 phase and neutral voltage waveforms

- Digital Fault Recorder
 - Fault detection using default limits
 - Programmable fault thresholds and hysteresis
 - Up to 50 amp fault currents ($10 I_n$)
 - Zero-sequence current and voltage calculations
 - Current and voltage unbalance
 - Under voltage, neutral current
 - Ready for use fault reports — fault current magnitude and duration, coincident voltage magnitude, fault waveforms and RMS trace

COMMUNICATION

- Reads 5 simultaneous independent communication ports (3 standard):
 - Infrared port (Modbus RTU/ASCII and DNP3.0 protocols). Supports IEC 62056-21/61 standard—hardware and protocol specifications for local meter data exchange
 - USB 2.0 full speed device port (Modbus RTU protocol, 12 Mbps) for fast local communications and data retrieval
 - RS485 universal serial communications port (up to 115,200 bps, Modbus RTU/ASCII and DNP3.0 protocols)

OPTIONAL ADD-ON I/O & COMMUNICATION MODULES

State-of-the-art communication abilities enabled by the EM920 concept:

- Ethernet 10/100 Base-T port (Modbus/TCP or DNP3.0/TCP protocols), up to five non-intrusive simultaneous connections, Telnet service port and RS232/485 user versatile port
- 1-ms satellite-synchronized clock—IRIG-B format timecode input
- Supports SNTP synchronization and cross trigger of events
- Dial Up modem module, (Modbus & DNP3.0 protocol) up to 56 kb/s

- Optional module cellular GPRS modem (Modbus/TCP or DNP3.0/TCP protocols)
- Optional IEC 61850 protocol
- Instrument firmware easy upgrade, using SATEC Power Analysis Software (PAS) via any communication port
- Master/Slave feature—reading of other meter registers or pass-through feature. Connect to other meters via RS485 and connect to SCADA master

INPUT/OUTPUT

- Two (2) independent digital inputs for Synchronization/Breaker Status/Counter functions—includes fast 1 kHz sampling rate
- KYZ relay output (Form C contact)
- Optional module with 8 digital inputs used for breaker status or pulse counting
- Optional Module for 6 relay outputs. 2 Form A (5A @ 250V AC/0.2A @ 250V AC) & 4 FORM C (0.15A @ 250V AC/DC)
- Optional 4CH Analog output module. 0-20mA, 4-20mA, ± 1 mA and 0-1mA
- AC/DC AUX. PS module: 50-288V AC, 90-290V DC
- DC/DC AUX. PS module: 24-48V DC

MASTER SLAVE MODE

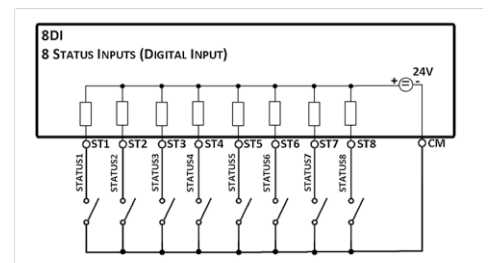
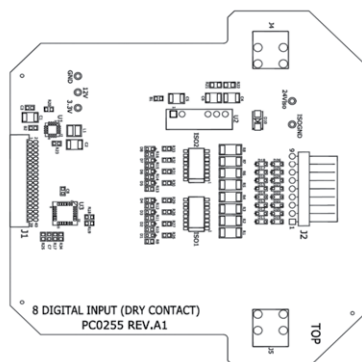
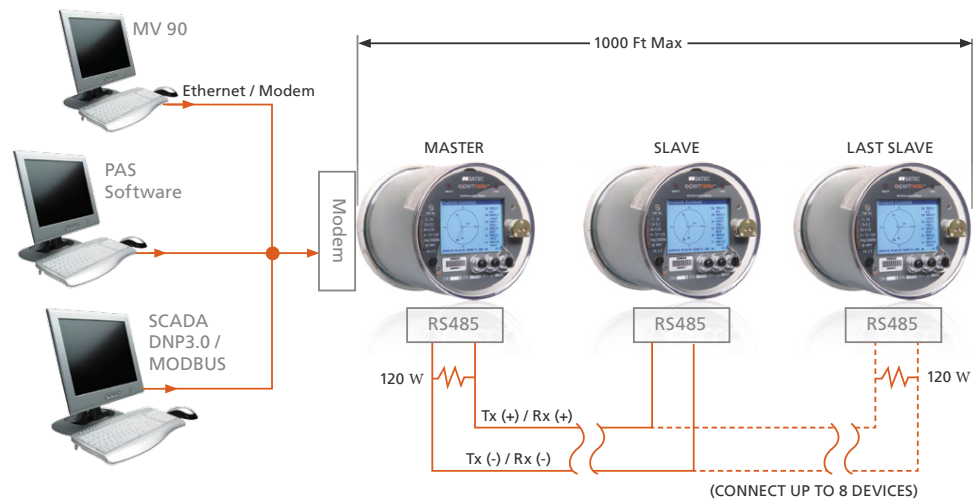

Standards Compliance Specifications

ACCURACY

- ANSI C12.20: Class 10/20: 0.25
- IEC 62053-22: Class 0.25

POWER QUALITY

- Harmonics and interharmonics measurement: IEC 61000-4-7 class I
- Flicker measurement: IEC 61000-4-15
- Power quality measurement methods: IEC 61000-4-30 class A/ EN 50160
- Real-time clock backup and accuracy: IEC 61038

POWER CONSUMPTION

- 5W or 20VA on each voltage input: ANSI C12.1-2008

EMC IMMUNITY

- AC Line Surge: IEEE/ANSI C62.41-2002
 - 100kHz ring wave @ 6kV/0.5kA
 - 1.2/50 μ s – 8/20 μ s Impulse @ 6kV / 3kA

- Magnetic Field: ANSI C12.1
- EFT/B: IEC 61000-4-4: level 4—4kV AC lines and 2kV I/O and COM lines
- SWC: IEEE/ANSI C37.90.1—2.5kV—measuring inputs, I/O and COM
- ESD: IEC 61000-4-2: level 4—15kV air discharge
- Radiation Susceptibility: ANSI C12.1

RADIO FREQUENCY EMISSION

- Radiation and Conducted emission: CFR47/FCC p.15 class B
- Construction, FORM 9S/A
- According to ANSI C12.1, ANSI C12.10

SAFETY

- UL/CSA 61010-1: 2006

INSULATION

- Insulation: ANSI C12.1—2.5kV AC @ 1mn

Measurement Specifications

Parameter	Full Scale@ Input Range	Accuracy			Range
		% Reading	% FS	Conditions	
Voltage V1-V3	120/207 x PT ratio @ 120V	0.05	±0.05	1% up to 140%	0 up to 999,000 V
Voltage V1-V3	69/120 x PT ratio	0.1	±0.05	1% up to 140%	0 up to 999,000 V
Voltage V4 (calculated)	69/120 x PT ratio		±0.5	5% up to 140%	
Line current I1-I4	CT primary current	±0.06	±0.06	1% up to 200% In	0 up to 100,000 A
Fault current I1-I4	CT primary current	±0.5	-	200%-1000% In	0 up to 100,000 A
Active power	3xV FSxCT/1000	0.2		PF ≥0.5 *	-10,000,000 kW to +10,000,000 kW
Reactive power	3xV FSxCT/1000	0.3	0.04	PF ≤0.9 *	-10,000,000 kvar to +10,000,000 kvar
Apparent power	3xV FSxCT/1000	0.2	0.02	PF ≥0.5 *	0 to 10,000,000 kVA
Power factor	1.000		0.3	PF ≥0.5, I≥2% FSI	0.999 to +1.000
Frequency	50 Hz	-	±0.02	40-65 Hz	40.00 up to 64.99Hz
	60 Hz	-	±0.02	45-70 Hz	45.00 up to 69.99Hz
Total harmonic distortion, THD	999.9	1.5	0.1	THD≥1%, V(I)≥10% FSV (FSI)	0 to 999.9
Total demand distortion, TDD, %	100		1.5	TDD≥1%, I≥10% FSI	0 to 100
Active energy import & export		ANSI C12.20 Class 20, Class 0.25			0 to 999,999.99 MWh
Reactive energy import & export		Class 0.5S under conditions as per IEC 62053-22:2003 @ 0≤ PF ≤0.9			0 to 999,999.99 Mvarh
Apparent energy		Class 0.2S under conditions as per IEC 62053-22:2003			
Symmetrical components	Voltage FS	1.0		10%-120% FS	As voltage
	Current FS	1.0		10%-120% FS	As current
	Current FS	3.0		200%-1000% FS	±180.0
Phasor angles		1 degree		*	

* @80% to 120% of voltage FS, 2% to 200% of current FS and frequency 50/60 Hz.

Physical Dimensions

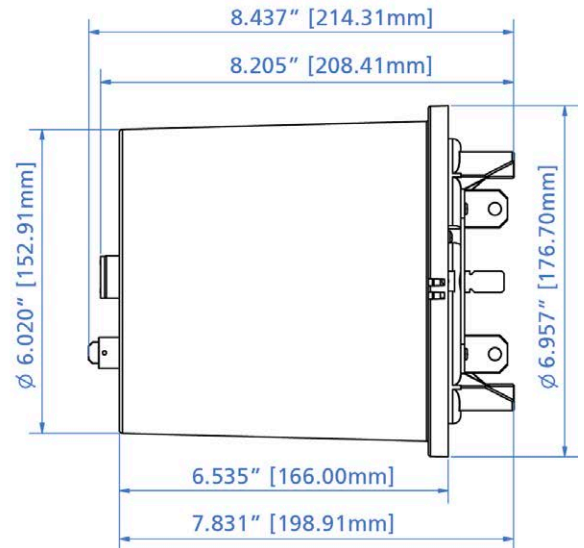
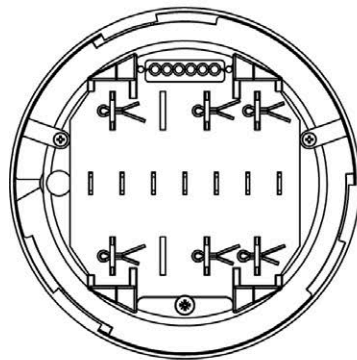

Technical Specifications

AC Voltage Inputs	3 voltage and 1 neutral inputs 50/60Hz	High input impedance >> 10MΩ
Reference voltage U_n 57.73V up to 120V L-N (standard) (via PT)	Voltage rating: 57.73 up to 120 Volts (L-N), 100 to 207 Volts (L-L)	
	Voltage range Crest factor >2 [$V_{L-N} \times 1.2 \times 2$]	0-144 V r.m.s, peak up 288V (for PQ)
	Maximum Line to Line voltage	500 V r.m.s
	Temporary over voltage between live conductors and earth Transient over voltage between live conductors and earth (optional, from 15 μs up to ms)	240 V r.m.s 1.5 kV peak
	Starting voltage ¹	0.1% U_n
	Burden per phase	< 0.2VA
	Overload withstand for 1 minute phase-to-ground (ANSI C12.1 & IEC 62053-22, protective class II)	4000V AC
	Rated impulse voltage (ANSI C12.1 & IEC 62052-11, protective class II)	6000V peak
	Terminals for wires size	Blades (Socket meter standard—C12.10)
	Reference voltage U_n 277V L-N (future option) (without PT)	Voltage rating: 277 Volts (L-N), 480 Volts (L-L)
Voltage range Crest factor >2 [$V_{L-N} \times 1.2 \times 2$]		0-332V r.m.s, peak up 665V (for PQ)
Maximum Line to Line voltage		1152V r.m.s
Temporary over voltage between live conductors and earth Transient over voltage between live conductors and earth (optional, from 15 μs up to ms)		1.5 kV r.m.s 6kV peak, 2kV possible measurement
Starting voltage		0.1% U_n
Burden per phase		< 0.5 VA
Overload withstand for 1 minute phase-to-ground (IEC 62053-22, protective class II)		4000V AC
Rated impulse voltage (ANSI C12.1 & IEC 62052-11, protective class II)		6000V peak
Terminals for wires size		Blades (Socket meter standard—C12.10)
Ground input		Terminals for wires size
AC Current Inputs	3 (4 optional) Galvanic isolated inputs	
Reference Current Basic model $I_n = 5A$ (TA = 2.5A)	Current class I_{max}	10A & 20A
	Maximum measurable short circuit current (I_{sc})	$10 \times I_n$
	Burden per phase ($I_n = 5 A$)	< 0.2 VA
	Starting current (I_1, I_2, I_3)	0.1% I_n
	Over current withstand for 1 s non-recurring	$50 \times I_n$
	Isolation	4000V AC
	Terminals for wires size	Blades (Socket meter standard – C12.10)
	3 (4 optional) Galvanic isolated Inputs	

¹ Starting voltage, interruptions and dips measurement applicable only with installed APS

Technical Specifications

Fast Status Input	Digital Input optically isolated	
2DI (standard)	Dry contacts, internally wetted	24V DC
8DI	Resistance of open contact sensing	> 1M Ω
Optional module	Resistance of closed contact sensing	< 100 Ω
	Sampling rate	1 ms
	Insulation Dielectric withstand	2500V AC @ 1mn
	Terminals for wires size	10 x 2.5 mm ² cable
RELAY OUTPUT		
Relay Output—KYZ (Standard)	Digital output – SSR optically isolated	1
	1 relay (Form C)	0.5A @ 250V AC/DC
	Operation time	1 ms
	Release time	1 ms
	Insulation Dielectric withstand	2500V AC @ 1mn
	Terminals for wires size	Blades (Socket meter standard—C12.10)
Relay Output	Digital output—combined SSR + EMR	2 x FORM C + 4 FORM A
6DO	SSR—4 relays (FORM C)	0.15A @ 250V AC/DC
Optional module	Operation time	1 ms
	Release time	1 ms
	Insulation Dielectric withstand	2500V AC @ 1mn
	EMR—2 relays (FORM A)	5A @ 250V AC
	Operation time	5-7 ms
	Release time	5-7 ms
	Insulation resistance of open contacts	> 2M Ω or 1000V @ 1mn
	Insulation Dielectric withstand	2500V AC @ 1mn
	Terminals for wires size	16 x 2.5 mm ² cable
Analog Outputs	Analog output galvanic isolated	4
4AO	Type of Outputs	4-20 mA default
Optional module		0-20 mA option
		0-1 mA (2mA max.) option
		\pm 1 mA (\pm 2mA max.) option
	Non-linearity	0.2%
	Load for 20 mA	<510 Ω
	Accuracy	0.5%
	Power supply	Internal
	Insulation Dielectric withstand	2500V AC @ 1mn
	Terminals for wires size	8 x 2.5 mm ² cable

Technical Specifications

Communication Ports

COM1	Built-in Infra Red communication port	Display unit
IR port (Standard)	RS232 communication, TTL level, max baud rate	19.2 kb/s
	Protocols	Modbus RTU/ASCII and DNP3.0
	Optically isolated	2500V AC @ 1mn
	Optical port per ANSI C12.18	Type 2
COM2	Plug-in modules communication port	Meter Shop installable
GSM/GPRS module—Optional	RS232 communication, TTL level, max baud rate	115.2 kb/s
	GSM/GPRS module	Quad Band GPRS class 10
	Protocols	Modbus/TCP or DNP3.0/TCP
	Isolation	2500V AC @ 1mn
	SMA connector	External antenna
Dial UP MODEM module—Optional (future option)	Wired line Dial-Up Modem module	Up to 56 kb/s
	RS232 communication, TTL level, max baud rate	115.2 kb/s
	Protocols	Modbus RTU/ASCII and DNP3.0
	Isolation	2500V AC @ 1mn
	MODEM module connector	Cable terminated with RJ-11 connector
COM3	Built-in serial communication port	
Standard	RS-485 isolated	115.2 kb/s
	Isolation	2500V AC @ 1mn
	Protocols	MASTER (Phase II) / SLAVE Modbus RTU/ASCII and DNP3.0
	Terminals for wires size	2 x 2.5 mm ² shielded twisted cable
COM4	Plug-in modules isolated communication port	Meter Shop installable
ETH-TX, DUP MODEM Optional module	Versatile RS-232/RS-422-485	
	Max. Baud rate	115.2 kb/s
	Isolation	2500V AC @ 1mn
	Protocols	Modbus RTU/ASCII and DNP3.0
	Terminals for wires size	5 x 2.5 mm ² shielded twisted cable
10/100Base-T	Plug-in modules network communication port	Meter Shop installable
ETHERNET-TX module—Optional	Wired LAN communication port with auto-negotiation	IEEE 802.3
	Ethernet port Baud rate	10/100 Mb/s
	Protocols	Modbus/TCP or DNP3.0/TCP protocols, up to five non-intrusive simultaneous connections, Telnet service port
	ETH port Isolation	2500V AC @ 1mn
	ETH connector	ETH cable terminated with Standard RJ-45 connector
USB	I/O and Communication port	Basic
FS device (Standard)	USB communication port	Full speed Device
	USB port Baud rate	12 Mb/s
	Protocols	Modbus RTU/ASCII and DNP3.0
	USB connector	Cable terminated with USB type A

Technical Specifications

Display Unit	4" Graphic LCD Display	320x240 dots resolution
	Energy LED Pulsing	2 x RED (WATT & VAR)
	IR port	ANSI C12.18
	Accessible Buttons—SCROLL, SELECT/ENTER	2
	Sealed Button—DEMAND RESET	1
	Under cover Button—TEST mode	1
Real-Time Clock	Programmable RTC, Error per month <15 s	1
Non-Volatile Memory	For energy and tariff registers logging, EV-PQ-DATA-WV log	16 MB
Power Supply	Supplied from monitored voltage inputs	
Low Voltage (standard)	Three Phase PS, Rated Inputs 50/60 Hz	57.73-120V AC \pm 20%
	Insulation Dielectric withstand	2500V AC @ 1mn
	Operating Temperature range	-40°C to + 85°C
	Output voltage	+12V DC \pm 5%
	Output power	7.5W maximum
High Voltage (future option)	Three Phase PS, Rated Inputs 50/60 Hz	120-277V AC \pm 20%
	Insulation Dielectric withstand	2500V AC @ 1mn
	Operating Temperature range	-40°C to +85°C
	Output voltage	+12V DC \pm 5%
	Output power	7.5W maximum
Auxiliary AC/DC Power Supply	Meter Shop Installable	
AC/DC Optional module	Operating Temperature range	-40°C to + 85°C
	Rated Input, 0-70 Hz	50-288V AC, 90-290V DC
	Isolation	2500V AC @ 1mn
	Output voltage	+12V DC \pm 5%
	Output power	7.5W maximum
	Terminals for wires size	2 x 2.5 mm ² pig-tail cable
24/48 VDC (Phase II) Optional module (future option)	Operating Temperature range	-40°C to + 85°C
	Rated Input	18.5-58V DC
	Insulation Dielectric withstand	3000V DC @ 1mn
	Output voltage	+12V DC \pm 5%
	Output power	7.5W maximum
	Terminals for wires size	2 x 2.5 mm ² pig-tail cable
Battery for RTC and SRAM	Minimum operation reserve 48 h.—if no use of battery (According to AS 1284.7/IEC 1038)	
	Total reserve capacity shall be not less than 2000h—with use of battery. (According to AS 1284.7/IEC 1038)	
	More than 10 years service battery life (According to AS 1284.7/IEC 1038)	
Environment Temperature	Operational temperature	-40°C to 75°C
	Optional LCD Operational temperature	-20°C to 70°C
	Storage temperature	-40°C to 85°C

EM920 ORDER STRING

MODEL

EM920—Form 9S
(includes 2DI, 1KYZ relay, USB, RS485 port) **EM920**

OPTIONS

VOLTAGE INPUTS

Standard - 120 up to 277 Volts AC (L-N) ± 20%
(208 to 480 volts L-L) **-**
(cannot be combined with auxiliary power supply)

Low Voltage 57.73 up to 120 Volts (L-N),
100 to 208 Volts (L-L) via PT **U**

CURRENT INPUTS

5 Ampere **5**

1 Ampere **1**

CALIBRATION AT FREQUENCY

60 Hz **60HZ**

50 Hz **50HZ**

TRANSIENT CAPTURE

Standard (256 samples per cycle) **-**

Transient module (transient over-voltages as short as 17 µs
are detectable, up to 2 kV amplitude is measurable) **TRM**

COMMUNICATION (MAX. 1 PER DEVICE)

Standard (USB, RS-485, IR) **-**

Ethernet TX, IRIG-B and additional RS-232/485 **ETH**

Ethernet TX, IRIG-B, additional RS-232/485,
plus IEC 61850 protocol **ETH-850**

2G/3G GSM Modem **T3G**

Dial Up Modem, IRIG-B and additional RS-232/485 **MOD**

INPUTS/OUTPUTS (MAX. 1 PER DEVICE)

No Inputs / Outputs **-**

6 Relays Output - 2 Form A & 4 Form C **6RLY**

8 Digital Inputs **8DI**

4 Analog Outputs ±1mA **4AO1**

4 Analog Outputs 0-1mA **4AO2**

4 Analog Outputs 0-20mA **4AO3**

4 Analog Outputs 4-20mA **4AO4**

AUXILIARY POWER SUPPLY (MAX. 1 PER DEVICE)

None **-**

50-288V AC and 40-290V DC
(cannot be combined with Standard voltage input) **AUX-ACDC**

TESTING AND CERTIFICATE

Full functional test,
calibration at various work loads & detailed test report **-**

Full functional test, calibration at various work loads &
detailed test report plus ISO 17025 and ILAC certified
calibration certificate **CC**

EM920

<input type="checkbox"/>	<input type="checkbox"/>	<input type="checkbox"/>	<input type="checkbox"/>	<input type="checkbox"/>	<input type="checkbox"/>	<input type="checkbox"/>	<input type="checkbox"/>	<input type="checkbox"/>
--------------------------	--------------------------	--------------------------	--------------------------	--------------------------	--------------------------	--------------------------	--------------------------	--------------------------

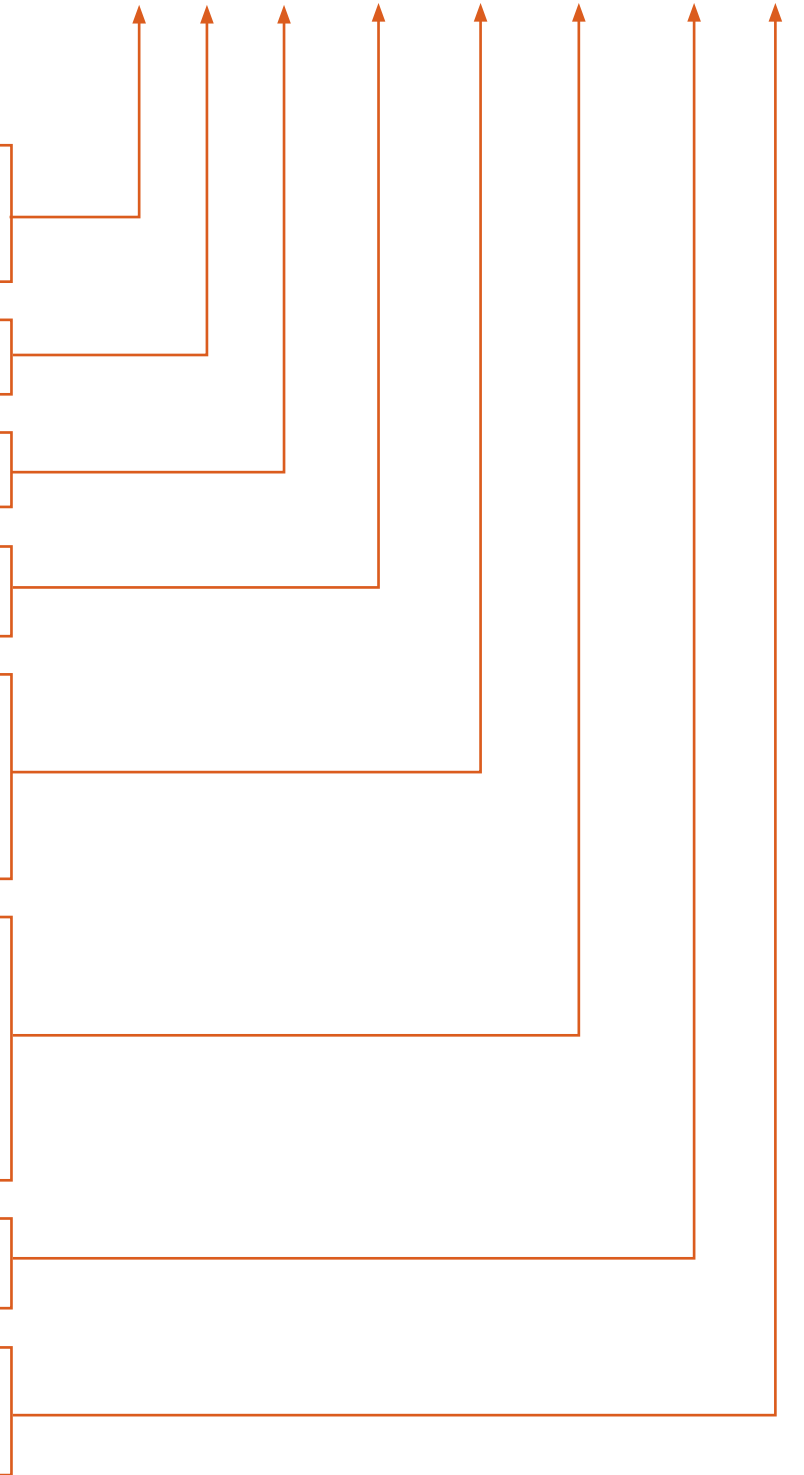

SATEC (Australia) Pty Ltd

PO Box 82, Mulgoa, NSW 2752

Phone: +61 2 4774 2959

Email: sales@satec-global.com.au

www.satec-global.com.au